

Econet Design and Installation Guide

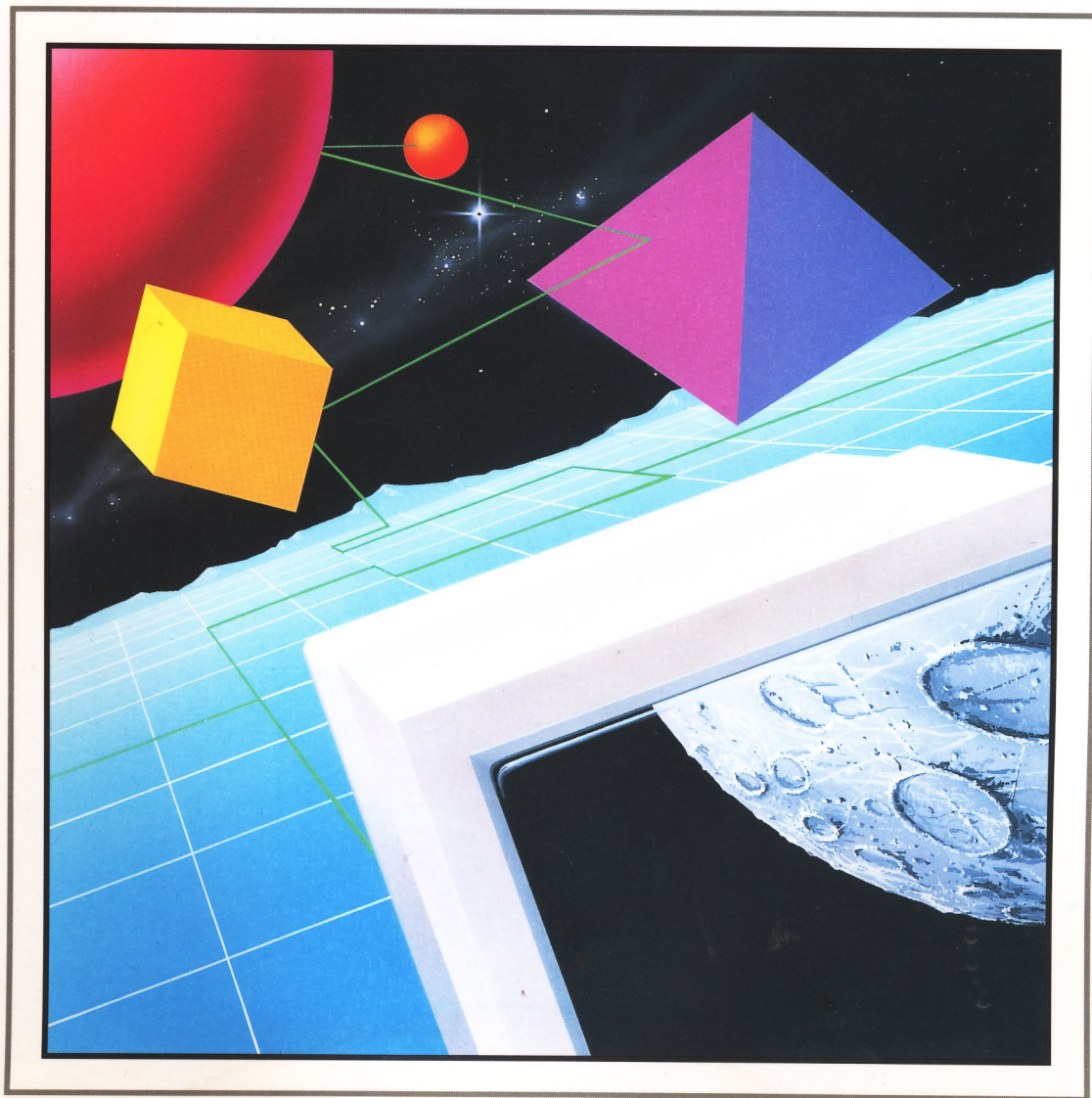

Acorn 

Econet Design and Installation Guide

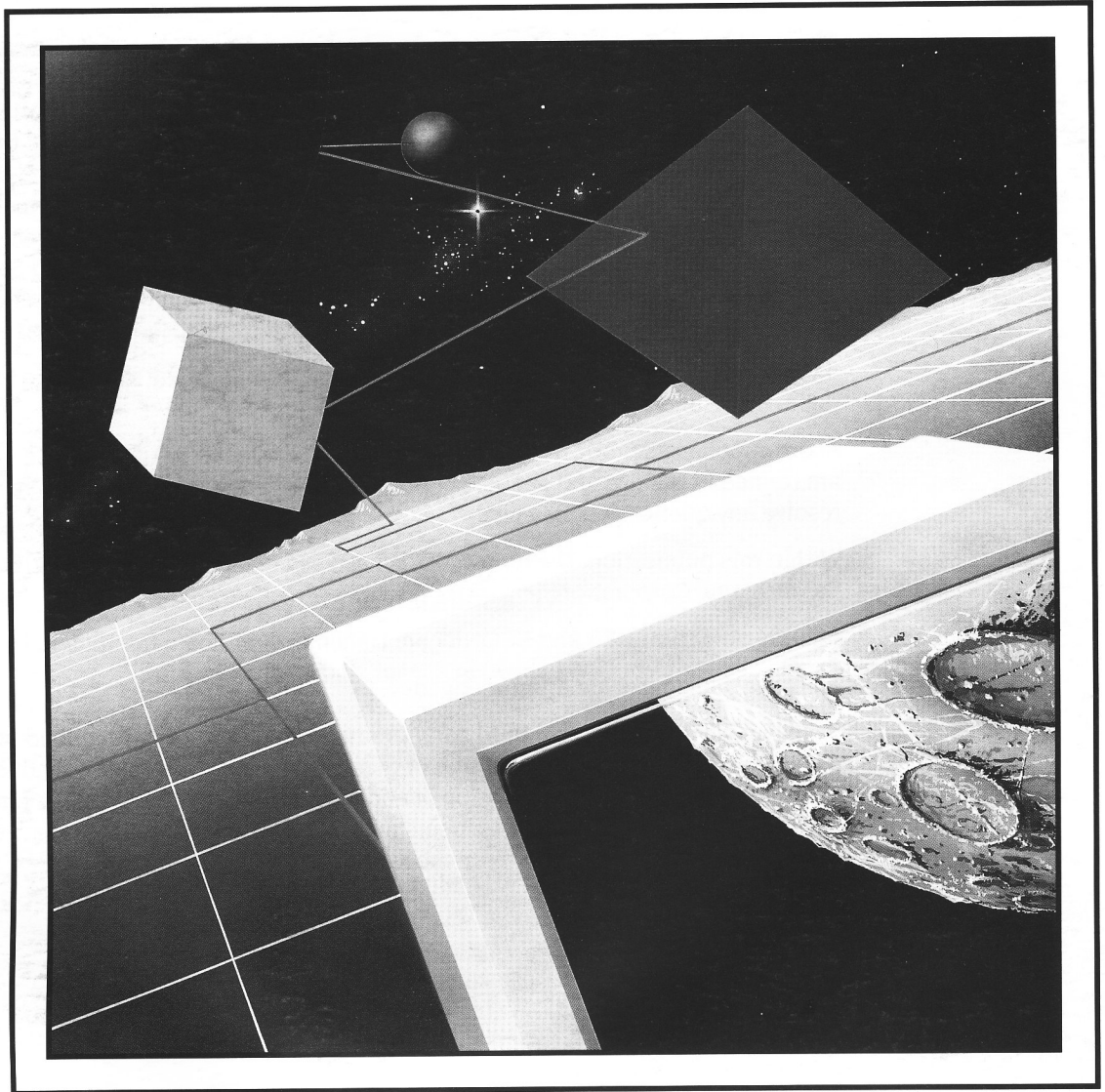

Acorn 

Copyright © Acorn Computers Limited 1993

Published by Acorn Computers Technical Publications Department

Neither the whole nor any part of the information contained in, nor the product described in, this manual may be adapted or reproduced in any material form except with the prior written approval of Acorn Computers Limited.

The products described in this manual and products for use with them are subject to continuous development and improvement. All information of a technical nature and particulars of the products and their use (including the information and particulars in this manual) are given by Acorn Computers Limited in good faith. However, Acorn Computers Limited cannot accept any liability for any loss or damage arising from the use of any information or particulars in this manual, or any incorrect use of the products. All maintenance and service on the products must be carried out by Acorn Computers' authorised dealers or Approved Service Centres. Acorn Computers Limited can accept no liability whatsoever for any loss or damage caused by service, maintenance or repair by unauthorised personnel.

If you have any comments on this manual, please complete the form at the back of the manual, and send it to the address given there.

Acorn supplies its products through an international dealer network. These outlets are trained in the use and support of Acorn products and are available to help resolve any queries you may have.

Within this publication, the term 'BBC' is used as an abbreviation for 'British Broadcasting Corporation'.

ACORN, ARCHIMEDES and ECONET are trademarks of Acorn Computers Limited.

All other trademarks are acknowledged.

Note: Various suppliers and third party products are depicted or described in this Guide. The illustration or description of these or any other third party products does not imply any recommendation or endorsement by Acorn Computers Limited of the suppliers or their products. Users must satisfy themselves as to the suitability of any product they may choose to buy.

Published by Acorn Computers Limited
Part number 0472,209
Issue 1, June 1993

Contents

Contents iii

About this guide vii

- Conventions used vii
- Finding out more viii
- Reader comments viii

1 Understanding network design 1

- What is a network? 1
- What you need to set up an Econet network 2
- What you might like to add to make your network more useful 3

2 Planning the network 5

- Single segment networks 5
- Campus networks 6
- Planning cabling 13

3 Installation considerations 17

- Planning 17
- Electricity supply for the network 17
- Work area 19

4 Cable requirements 21

- Econet cable 21
- Econet leads 23

5 Trunking requirements 25

- Do you need trunking? 25
- Trunking for the Econet cable only 26
- Trunking for Econet and mains wiring 26
- Installing mains sockets 27
- External cabling 28
- Safety 28

6 The Econet clock 29

- Why do you need a clock? 29
- Positioning the clock 29
- Econet clocks 30

7 Terminators 47

- Why terminate a network? 47

8 Socket boxes 51

- Econet socket boxes 51
- Acorn socket boxes 52
- SJ Research socket boxes 53
- Soldered 5-pin DIN sockets 53
- Digital Services solderless crimp outlets 54

9 Interference on the network 57

- The Econet interface 57
- Mains-borne interference 61

10 Installation 67

- Tools required 67
- Removing the earth shielding 67
- Wiring Acorn socket boxes 68
- Wiring SJ Research socket boxes 69
- Joining cable lengths 71
- SJ Research transient suppressors 74

11 Testing the network 75

- Connecting the clock and terminators 75
- Equipment 75
- Testing for cable breaks 77
- Identifying faulty Econet interfaces 82
- Identifying faulty bridges 84
- AC testing 86

12 Commissioning the network 91

- Adding a new station to the network 91

13 Expanding existing Econet networks 103

- Planning network expansion 103
- Linking buildings 106

Appendix A: Error messages on client terminals 109

Appendix B: Econet file server error messages 113
ADFS errors 126

Appendix C: About NETMON 129

Appendix D: Software available on the Acorn Support BBS 137

Appendix E: Tools required 139

Appendix F: BSI standards 141

Appendix G: Econet interface options for the A3020 and A4000 143

Appendix H: Glossary 145

Appendix I: Useful addresses 147

- Acorn addresses 147
- Health and safety publishers 148
- Cable suppliers 148
- Network suppliers 149
- Component suppliers 149
- Test software suppliers 150
- Static specialists 150
- Interference specialists 150
- Rental equipment suppliers 152

Appendix J: Circuit diagrams 153

About this guide

This document explains how to design, install and commission a new Econet network. All aspects of installation are covered, including how to test an existing network. Examples of test procedures and expected readings are given along with simple examples of the way data is handled by the computer.

Chapters 1 to 3 give a general overview of Econet installations, and how to plan the network.

Chapters 4 to 9 give a more detailed breakdown of Econet network components. These chapters are for information only; you are advised to seek further advice and professional assistance from your local network support agency.

Chapters 10 to 13 give a general overview of how to install and test an Econet network, how to get it up and running and how to expand your network. Again, you are advised to seek professional assistance from your local network support agency rather than attempt to do this yourself.

Where appropriate, reference is made within this guide to a selection of third party products and their suppliers.

Conventions used

Certain conventions are used in this guide:

Typefaces

`Courier` type is used for the text of example files and commands. Since all characters are the same width in Courier, this makes it easier for you to tell where there should be spaces.

Courier type is used in some examples to show input from the user. It is also used in some examples to highlight items in the computer output.

Command syntax

Special symbols are used when defining the syntax for commands:

- Italics indicate an actual value. For example, *filename* means an actual filename is, or should be, supplied.
- Braces indicates that the item enclosed is optional. For example, [d] shows that you may omit the letter 'd', and [d] means that you may omit the value 'd'.

Finding out more

For details of how to set up and maintain your computer, refer to the *User Guide* or *Welcome Guide* supplied with your computer. For details on the use of your computer and of its application suite, refer to the guides supplied with it.

Reader comments

If you have any comments on this guide, please complete the form at the back of the manual and send it to the address given there.

1

Understanding network design

Designing and installing a network requires quite a lot of expertise and knowledge, both technical and practical. You are strongly advised to get your local network support agency to do this work for you, as they have the necessary skills to ensure that your network runs as quickly, reliably and efficiently as possible.

The rest of this chapter will help you to understand the choices available, to provide the information that your dealer will need, and hence mutually to reach a sensible decision on the layout and future development of your Econet network. It also tells you what limitations there are, should you decide to have stations or cabling added to existing installations.

What is a network?

A network is a chain of interconnected computers which are able to load and save data from a shared storage resource, a file server. A network allows the computers to communicate with each other, and to share resources, such as printers.

A file server provides a central storage facility for programs and data files for the network, and runs the software utilities which control the network.

On an Econet network:

- Network stations are connected via socket boxes to a permanently-installed cable.
- Programs and data pass along the network cable in the form of electrical signals which are synchronised by the network clock.
- When electrical signals are transmitted along a cable, they can be reflected at the ends of the cable. These reflections can interfere with the main signal. To prevent these reflections, terminators must be fitted at each end of the cable.

BBC Model B, Master 128, Master Compact and Archimedes computers which have been fitted with an Econet interface can happily co-exist on an Econet network.

Note that computers which are attached to a network and sharing network facilities, have a variety of names; they are commonly called network stations, workstations, network terminals and client machines.

This document covers Econet, Acorn's own network system. If you are planning to expand an existing Econet network, you should consider Acorn's current networking strategy, Acorn Universal Network (AUN). AUN supports both Econet and Ethernet (the network industry standard), and runs more quickly and efficiently than Econet.

What you need to set up an Econet network

To set up a single segment Econet network, you need

- network cable
- network clock
- two terminators
- a file server
- network stations (computers)
- connection points for network stations.

Acorn produces Econet Starter Kits. The current Acorn Econet Starter Kit comprises SJ Research components:

- an SJ Research Econet clock
- two SJ Research terminators
- two SJ Research twin socket boxes
- a plastic IDC insertion tool
- an installation kit for the SJ Research clock comprising:
 - two secure terminator boxes
 - a split socket box.

The previous Acorn Econet Starter Kit comprised:

- an Acorn Econet clock
- two Acorn terminators
- three Acorn twin socket boxes
- two Econet drop leads
- a plastic IDC insertion tool.

Both kits allow a total of 6 machines to be connected to the network. The SJ Research split socket box provides the same functionality as two Acorn twin socket boxes and two Econet drop leads.

The current Econet socket kit contains five SJ Research twin socket boxes providing connection points for ten machines.

What you might like to add to make your network more useful

As your network develops you may wish to add other shared facilities such as:

- a printer server
- bridges.

A printer server allows a computer on the network to print text or graphics to paper. All the computers which are connected to the network can use this facility.

Bridges are used to connect separate networks on the same site, and one or more are required when a network needs to be extended beyond 500m. The bridge is transparent to the user and allows programs, data, file servers and printers to be shared by computers on other networks. Up to 127 Econet networks may be connected in this way.

What you might like to add to make your network more useful

2

Planning the network

An Econet network comprises one or more network segments, each of which may be up to 500m in length.

There are a number of ways to implement an Econet network, depending on the size and layout or topology of the network to be installed. Econet installations can be classified into two typical types:

- A network of up to 500 metres in length (a single segment network)
- An extensive campus network (an extensive network comprising more than one network segment).

Single segment networks

A single segment network is suitable for networks up to 500 metres in length. *Figure 2.1: Typical single segment network configuration* shows a single network configuration, comprising permanent **uncut** cabling, socket boxes, terminators and a clock box. Conceptually, all networks should be made from this base installation:

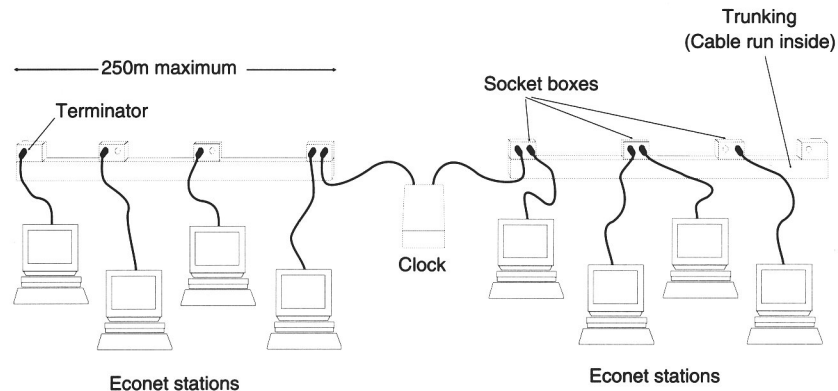

Figure 2.1: Typical single segment network configuration

Up to 254 stations may be connected to a single segment network.

A terminator box is required at each end of the cable, with a clock box in the middle to time the transmission of the data across the cable.

If a FileStore is connected to a network which already has a clock, its internal clock and termination facilities are automatically disabled.

The connection between the main Econet network cable and a station is made using an Econet drop-lead which is limited to a length of 2 metres. This restricts the design of the network, and is often inconvenient, for example when the network has to service several floors of a building.

Campus networks

You can build an extensive campus network comprising more than one network segment using bridges to join network segments together. Up to 127 network segments may be joined together through bridges.

By using networks with one or more bridges, more useful network layouts may be constructed.

The following sections look at three example network layouts requiring bridges; a linear, a star-type and an E-type design. The examples are represented in schematic form using the following key:

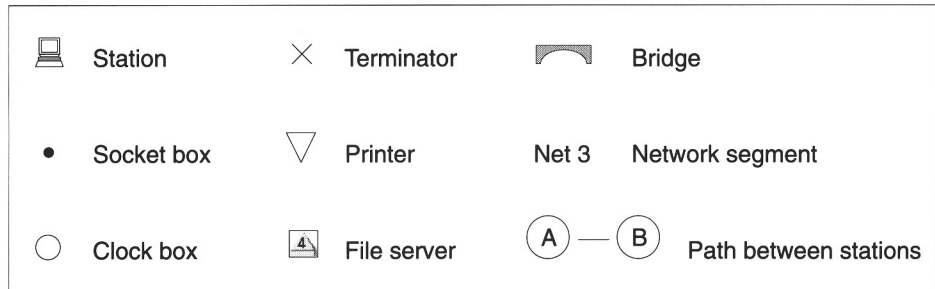

Linear networks

A linear network is the usual first stage of network expansion as it is the most cost effective method of linking two or more networks together.

In certain circumstances a linear network layout can prove inefficient, especially if higher demand is likely to be placed on the network at certain times of the day such as at the start of a lesson in a school. Consider *Figure 2.2: Two networks linked by a bridge*:

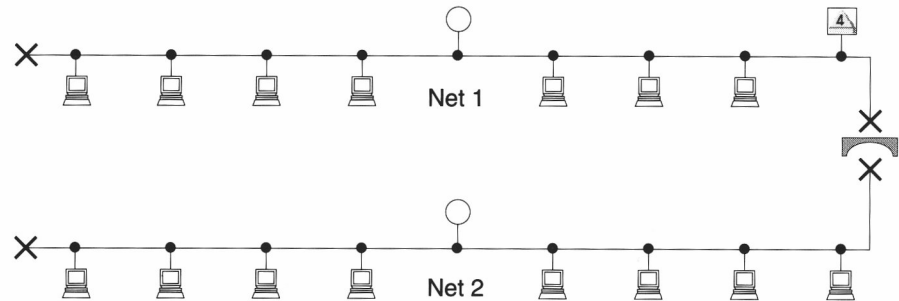

Figure 2.2: Two networks linked by a bridge

If you look at the data transfer which takes place on this network you can see that there are circumstances when the whole network is prevented from functioning at its optimum speed.

Consider a station on network 1 communicating with the file server on network 1:

- 1 The station searches all the networks to see if there are any file servers.
- 2 The station sees that there is a file server on the network, and obtains information about it. This information consists of the names of any discs attached to it, its station number and network number. The computer, depending upon the type, is then able to access the file server either by the name of one of its discs, or by its network and station number.
- 3 The station asks the file server, "Are you there?".
- 4 If the file server is not busy, it replies.
- 5 The station then begins a dialogue with the file server enabling it to load or save data.

From the moment the station makes the request to the file server **all** other machines are prevented from sending messages to the local network. All other networks are unaffected because the bridge recognises that the communication between the machines is local (on the same network segment) and so prevents it travelling to other segments of the network.

Communication is similar between points A and B in Figure 2.3: *Communication path between two remote stations on a bridged network*, as all the machines have the same chance of communicating with the file server.

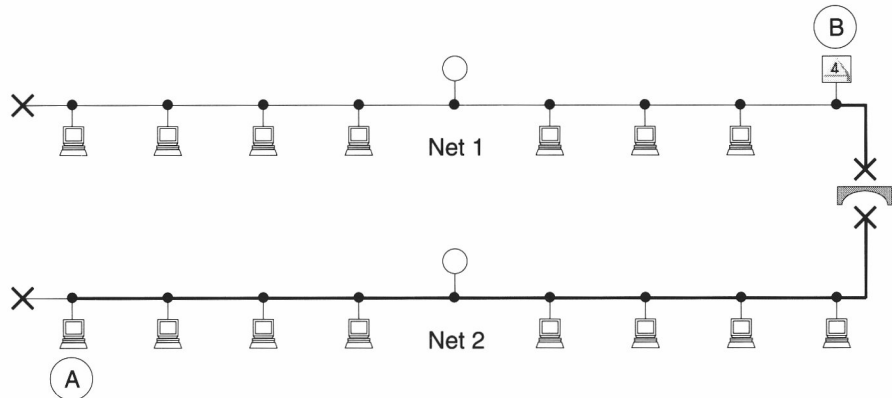

Figure 2.3: *Communication path between two remote stations on a bridged network*

The bridge allows this communication to take place and mimics what would happen if the stations were on the same local network:

- 1 The station on network 2 asks the file server on network 1, "Are you there?".
- 2 The bridge recognises that the file server the station is asking for is on a different network, which it knows about. The bridge therefore collects the message "Are you there?" and forwards it on.

While this communication takes place, the bridge sends a stream of flags onto network 2, to prevent other stations from claiming the line. The process is called flag fill.

- 3 If the file server is not busy, it replies.
- 4 The bridge recognises that the station the file server is asking for is on a different network, which it knows about. The bridge therefore collects the response from the file server, and forwards it on.

While this communication takes place, the bridge sends a stream of flags onto network 1, to prevent other stations from claiming the line.

- 5 When the station has received the reply the bridge ceases to flag fill network 1, allowing another machine to access the network.

You should note that the dialogue between the two stations and the bridge is actually more complex as each bridge in the chain slows communication down slightly.

If you consider *Figure 2.4: A linear multiple segment network*, you can see that, in the worst case, all but one of the networks are affected by the communication between station A and the file server B.

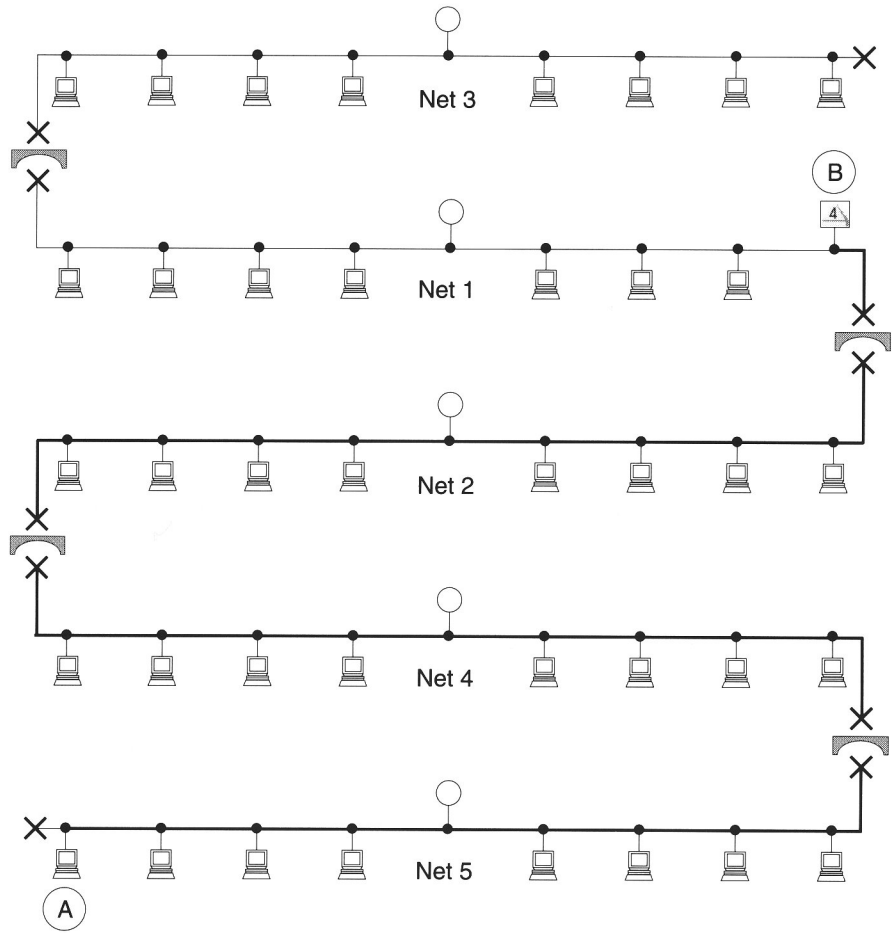

Figure 2.4: A linear multiple segment network

In *Figure 2.4: A linear multiple segment network* the chances of stations on networks 4 and 5 being unable to achieve reliable communication with the file server are quite high. This network is badly structured, and the priority of the networks is wrong.

If you look at the order of priority of communication you can see:

Network 1	Highest priority
Network 2 and Network 3	(Both have an equal chance)
Network 4	
Network 5	Lowest priority

In certain circumstances this type of network topology would prove unusable, but it could be dramatically improved by simply providing each network with its own local file server.

Correct structuring of the data etc would keep the inter-segment traffic to a minimum and yet still enable full communication when required. This would give an effective increase in data transfer rates of up to 500%, as all the networks could operate simultaneously instead of sequentially.

Star-type networks

Another common type of network layout has a centralised main network segment with several outlying segments. This design is used in schools and colleges where the main network, printer servers and file servers are in the computer room; other rooms, possibly in different buildings, have their own network segments attached to this.

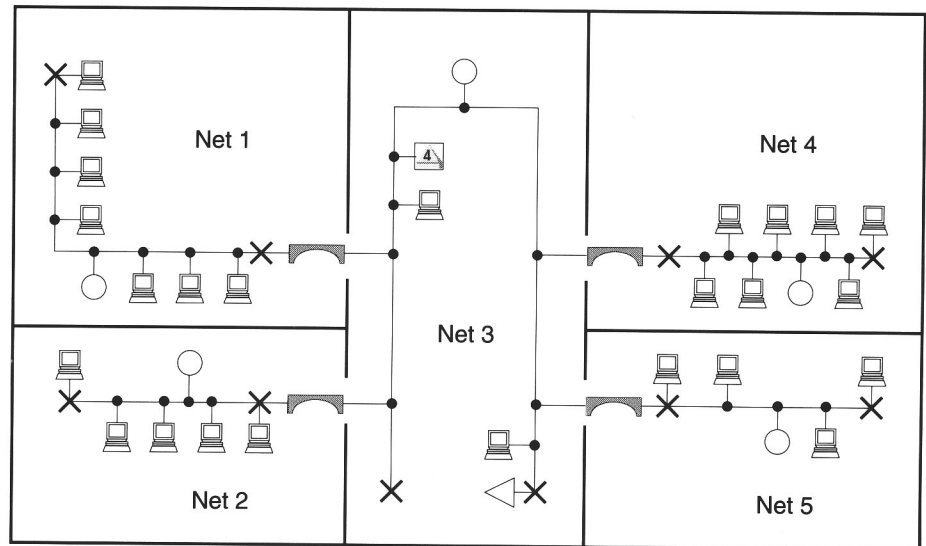

Figure 2.5: A star-type topology

In Figure 2.5: A star-type topology network segment 3 is the main segment, the others forming branches out from this through the bridges.

Stations on each network segment may reach stations on any other network segment; messages pass through up to two bridges.

No message may reach its destination by more than one route.

When connecting network segments using bridges, it is vital that there are no duplicated routes forming loops between any of the systems. If the number of bridges is equal to or greater than the number network segments, there is bound to be a loop, and one or more of the bridges must be removed.

E-type networks

The E-type network topology uses the concept of a backbone. In *Figure 2.6: An E type topology* the backbone is shown running up the height of the building, with a bridge on each floor connecting the vertical network to each horizontal floor network. This topology can also be applied to a flat model, where the backbone connects networks in different buildings on the same site.

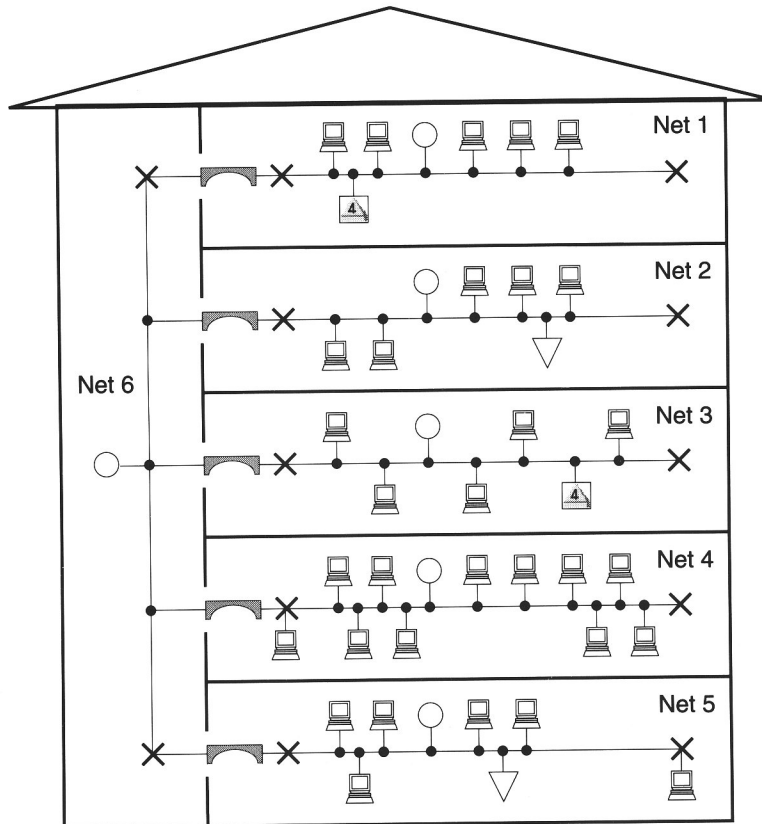

Figure 2.6: An E type topology

In the figure, the terminators of network segments 1 to 5 are connected to the terminator or socket boxes of network segment 6 by bridges, as shown.

There is no need for all of the networks in the system to have a file server. In particular the backbone, network 6, does not need a file server as the cable acts only as a connection between the other networks. This also ensures that the chances of it being available for data transfer are always high, and would be especially true if each of network segments 1 to 5 had their own file server.

If we consider the path that **any** station would need to take to communicate with another station we find that in every case the maximum path is:

Local network → Bridge → Backbone → Bridge → Remote network

When the network is viewed from network 1 the priorities are:

Network 1	Highest priority
Network 6	
Network 2, Network 3, Network 4 and Network 5	Lowest priority

This is the optimum configuration for any multiple network, as it minimises the number of networks and bridges through which data is passed.

Planning cabling

When planning the Econet cabling:

- always use the correct cable
- do not cut the cable unless you have to
- do not use sockets which require making soldered connections directly between the Econet cable and the DIN socket or PCB
- keep the length of each cable run to a minimum (a long cable means a slower network, and less scope to extend the network without using multiple networks and bridges).

Planning cable runs

Consider this situation. Ten stations are to be placed on a worktop along one wall of a room. The wall is 10m long, and the worktop is at a height of 1m. The floor to ceiling height is 3m. The floor is made of wood and the ceiling is of a suspended design. Five socket boxes are needed.

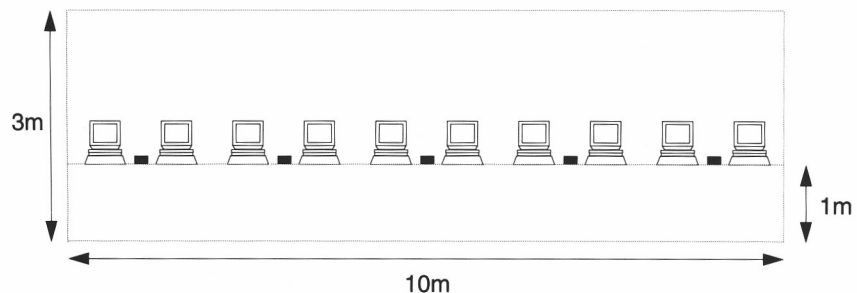

Here are three routes that the cable could take. The total length of the cable run is calculated as the length of the worktop plus the cable rise and fall multiplied by the number of sockets.

Route 1 Lay the cable in the ceiling and run down to each socket box and back again.

Approximate total length = $10 + ((2+2) \times 5) = 30\text{m}$

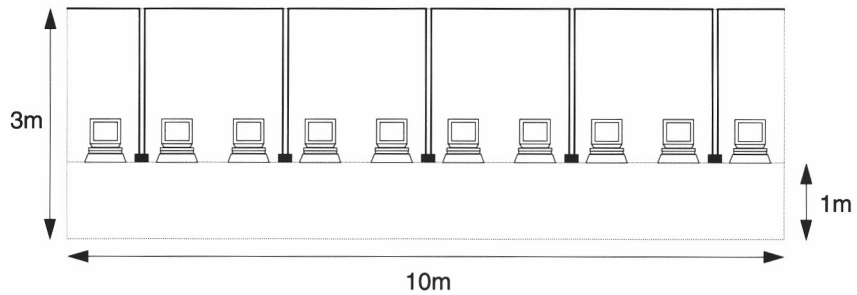

Route 2 Lay the cable in the floor and run up and down for each socket box.

Approximate total length = $10 + (1+1) \times 5 = 20\text{m}$

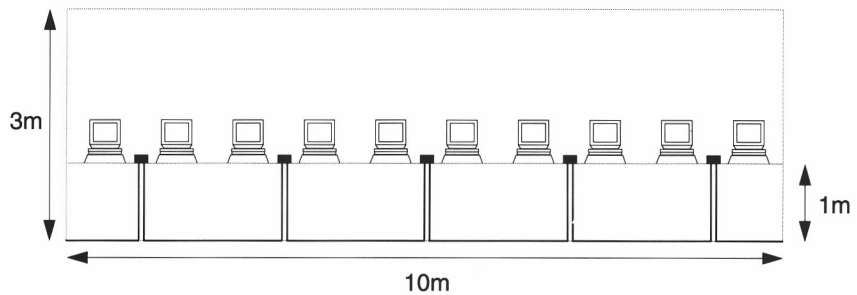

Route 3 Run the cable along the worktop, against the wall.

Total cable length = $10 + (0 \times 5) = 10\text{m}$

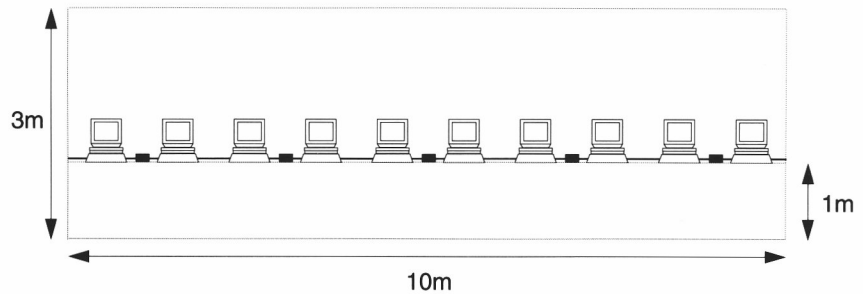

From these examples, you can see that the route which the cable takes is important if you want to maximise the performance of the network.

It's also worth noting that the shorter the route, the less you have to spend on cable and its installation costs!

Not cutting the cable

Networks in which the cable has been cut at each socket box fail to perform at optimum levels. Each break in the cable is a potential source of problems, particularly signal degradation due to reflections from the cut ends interfering with the main signals. Other problems come to light as more machines are placed on the network or as the cable length is extended.

It's not much fun pulling large amounts of cable holes in the wall, but it is good practice. To reduce the amount of force required to feed cable through, and to minimise the likelihood of damage to the cable, you are advised to start at the middle of the run.

It's harder to remove the outer insulation from the middle of the cable than it is from the end, but your network will suffer if you cut the cable.

If your installer advocates gratuitously cutting the cable, you are advised to seek another installer.

3

Installation considerations

This chapter deals with the factors which must be taken into account before and during the installation of a network.

Installers and consultants are advised to consult the appropriate Health and Safety Regulations during the design phase of the installation. In the UK, documents such as *About working with Display Screen Equipment* by Scriptographic Publications Ltd or those published by the Health and Safety Commission provide good references.

Planning

When installing a network you should, as much as possible, adhere strictly to the following guidelines:

- Keep cable runs as short as possible.
- Design cable runs so that the cable does not have to be cut.
- Install conduit or trunking for the cable.
- Keep Econet cable and mains cable as far apart as possible.
- Ensure the clock is placed as close to the centre of the network as possible.
- Ensure that there are only two ends to the cable and both of these are terminated.

Additionally, consideration should also be given to the mains supply for the computers and network, and to the work area required by each user and computer.

Electricity supply for the network

The quality of the electricity supply which provides the power to the network and its computers is very important if the network is to be reliable. For further information on problems that may be caused by the electricity supply, see *Interference on the network* on page 57.

Isolating switches

In some circumstances, for example in a school, it is desirable to have a central switch, or isolator, which turns the power off to all the equipment in a room. Where this facility is available it is advisable to ensure that the following components are **not** powered down by the isolating switch:

- all Econet file servers
- all Econet clocks
- all Econet bridges.

If the power to a file server is suddenly switched off before the correct shutdown procedure has taken place valuable data can be lost. The file server stores data it needs in its cache so that it can optimise the disc operations and ensure the fastest response to any requests for data. If the power is suddenly switched off or interrupted then this data will be lost. This can generate a number of errors, from the error `Broken directory` to complete hard disc failure.

Your network may run through a number of rooms or link buildings together. The machines all rely on the clock to be present in order to be able to use the network. Switching the clock off prevents users from using the network. This could be inconvenient if they are using the network as shown here:

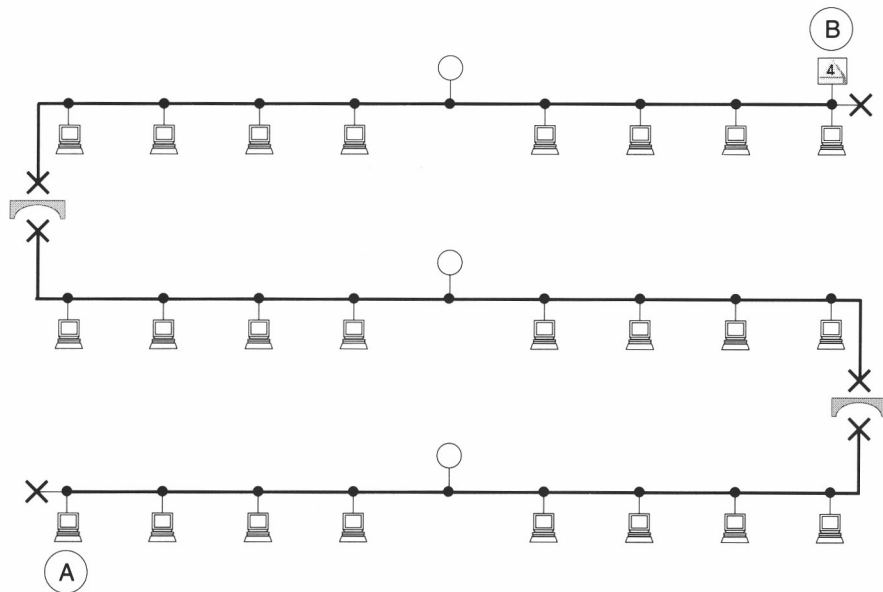

Figure 3.1: Communication path between a station and a file server

If each of the networks is 500m long and a person working at point A is using the file server at point B then switching the clock off on network 1 or 2 would prevent them communicating with the file server. The user would be informed that the file server is `Not listening`, not that the clock on network 1 or 2 has been switched off.

Econet bridges are affected in the same way as clocks.

Work area

When planning an installation you should consider the working environment. Factors which affect the user and work area are:

- static
- dust
- space.

Static

Man-made fibres are used in floor coverings and clothing, and so most installations are subject to regular static discharges. Static discharges may intermittently cause computer programs to crash.

Buildings with air conditioning are more prone to static discharges, and the use of air ionisers can help reduce the problem.

If you do have a lot of trouble with static, you can also use anti-static spray on the keyboard (which is the area most likely to be affected), and earthing mats under the keyboard and computer, and on the floor.

Anti-static flooring is also available.

Static-measuring voltmeters can be used to locate area of serious static build-up. Some static specialists are also willing to arrange a free visit to your site to analyse the problem and offer advice.

Dust

It is a good idea to carpet the room(s) on the network to prevent problems with dust. When specifying floor materials, avoid pure nylon carpets and check with the manufacturer about the static properties of the products you wish to use.

Space

You should consider the amount of desk area which a computer requires. Badly positioned equipment can cause the user back, neck and eye problems.

As a general rule the minimum desk area for the largest of the Archimedes range of computers is 0.75m x 0.775m, as shown in *Figure 3.2: Footprint of an Archimedes machine, monitor and mouse mat*. However 0.8m x 1m provides better access to the floppy disc drive, and allows room for a wrist rest in front of the keyboard.

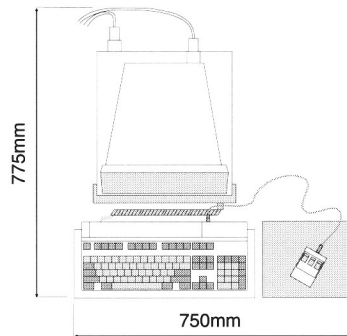

Figure 3.2: Footprint of an Archimedes machine, monitor and mouse mat

Temperature

You should make sure that file servers, printer servers, bridges and discs are not subjected to extremes of heat. Discs are especially sensitive to rapid changes in temperature.

Keep the equipment away from direct sunlight, radiators, heaters and other forms of heat. You should also consider seasonal variations which may affect the temperature of the area.

Remember that top shelves are generally hotter than lower shelves, and if necessary, consider installing a ventilating system.

Security

It is important to keep expensive electronic equipment out of harm's way. File servers, bridges etc should be preferably locked away in a well-ventilated area where they cannot be interfered with.

4

Cable requirements

This chapter explains the type of cable you need to use when you install an Econet network, and how to plan the installation of your cable.

You **must** use the correct type of cable when installing an Econet network. Resist the temptation to install a cheaper grade of cable which is superficially similar to the specified grade, as your network will not work properly. You are advised to seek professional assistance from your local network supply agency when assessing your cable requirements.

Econet cable

The quality of the cable you use in your installation is very important. Econet cable has twisted pairs of wires, each pair having a different twist ratio.

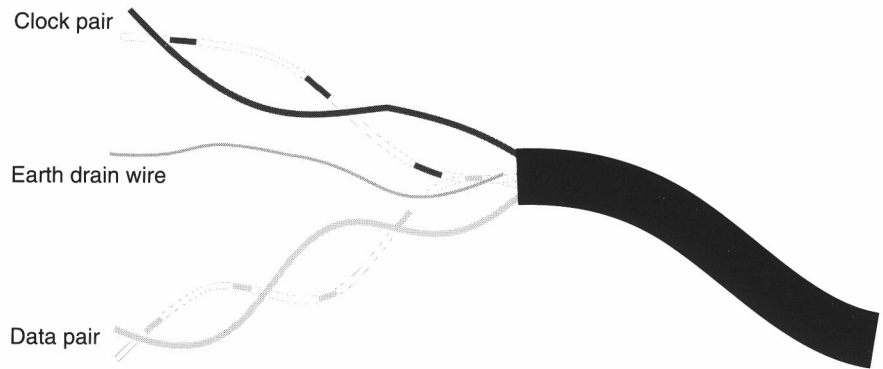

Figure 4.1: Different twist ratios of pairs of wires in Acorn Econet cable

Cable which is suitable for use in an Econet installation can be obtained from the following sources:

Supplier	Stock Code	Reel Length
Acorn	AEH17	100m
BICC	H8064	
Brand Rex	CD 84-4-0521	
SJ Research	CBL 1E03	100m
SJ Research	CBL 5E03	500m

Address of suppliers are given in *Appendix I: Useful addresses*.

Econet requires two clock and two data signals in order to operate:

- The clock signals, Clock + and Clock -, are equal but opposite to each other (they are 180 degrees out of phase).
- The Data + and Data - signals are also out of phase, but there is a very slight difference between the value of the voltages when the network is idle which is determined by the terminators.

The use of twisted pairs ensures that:

- The two wires are kept as close together as possible, thereby ensuring that crosstalk to other wires is reduced to a minimum.
- The voltages picked up in one twist length of each twisted pair are cancelled out by equal voltages picked up in the other twist length of the same twisted pair.

Providing that the Clock + and Clock - signals are restricted to one twisted pair in the cable, the interference can be cancelled out by using a differential comparator which compares the voltage difference between the two signals. This is one of the functions of the Econet interface which is fitted to each computer on the network.

Selecting suitable cable

If you cannot obtain cable from these suppliers, you must select cable which meets the following specification:

- The cable must have:
 - characteristic impedance $100 \text{ ohms} \pm 10\%$
 - mutual capacitance $< 66 \text{ pF/Metre}$
 - propagation speed $> 0.5c$ (where c = the speed of light)

- earth conductor diameter between 0.4mm and 0.63mm single stranded (multi-strand earth is not acceptable as it has no sleeve support)
- individually insulated conductor diameter between 0.4mm and 0.63mm single stranded, or 7/0.15 to 7/0.2 multi strand.
- The cable must consist of 2 twisted pairs with a separate drain wire, (ground), which runs in contact with an earth shield. The minimum shield should be a layer of foil, but cable with a layer of foil and a braided sleeve may be more suitable if the cable installation is near to equipment with high RF emission levels, such as TV and radio transmitters, or run near noisy electrical equipment or wiring.
- Each individual core must consist of a conductor which conforms to the specified diameter. Conductors of different diameters will not make adequate connection with the IDC (Insulation Displacement Connector) socket and may damage it.
- The cable must have a flame-retardant outer sleeving.

Econet leads

A drop-lead known as an Econet lead is used to connect the computer to the network.

An Econet lead may be up to 2m long, and typically has a 180 degree 5-pin DIN plug at each end, although connections for your computer may differ. It is recommended that you use leads with the plugs moulded onto the end. This helps prevent intermittent faults and *Line jammed* errors on the network. The use of leads connected by 5 pin DIN T-pieces is **not** recommended on any installation.

There are numerous types of drop leads available. To ensure full earth continuity from the network to the machine, you should use a lead which comprises four individually screened wires connected to pins 1,3,4,5 and the individual lapped screens from those wires connected to pin 2 and the outer metal screen of the plug. Other similar leads should not be used as they may cause unreliable operation.

5

Trunking requirements

This chapter explains the types of trunking you need to use when you install an Econet network.

You **must** use the correct type of trunking when installing an Econet network. You are advised to seek professional advice on all aspects of mains wiring from a qualified electrical engineer.

Do you need trunking?

Econet cable is designed for use with data voltages only. This means that the Econet cable can be installed by a person without electrical qualifications, provided that it will not come into contact with any mains cabling, wiring or voltages.

Econet cable itself can constitute a safety hazard if it is run loosely through a work or access area. The cable should be routed to prevent damage to the cable or injury to people (for example, injury may result from tripping over badly-routed cable).

The cable should always, as a minimum, be attached to a solid structure at short regular intervals by clips. BS 6701 specifies intervals of 300mm on unsupported runs, 400mm on supported runs and 1m on vertical runs. Make sure that there are no sharp bends in the cable.

If the cable will be readily accessible or has to be routed through a hostile environment, you need to use conduit or trunking.

Trunking for the Econet cable only

Flat plastic trunking with a removable top cover is recommended. This type of trunking makes life easier when you are removing the cable's outer insulation because you can take the cable out of the trunking while you do work. Flat plastic trunking also gives you easier access to components inside socket boxes.

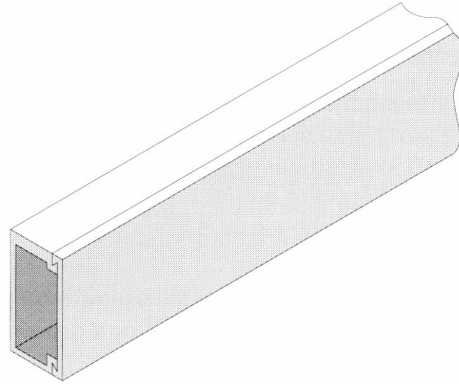
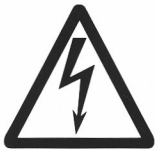

Figure 5.1: Trunking with a removable top cover

The minimum recommended size of trunking is 38mm wide x 25mm high. This allows a socket box to butt up neatly to the top or bottom edge of the trunking, providing a flush front surface. Trunking of this size also allows the cable to bend in a smooth arc into the socket box preventing undue stress on the edges of the IDC.

This type of trunking must NOT be used to carry mains and Econet cable together.

Trunking for Econet and mains wiring



This section is based upon current UK practice. Although the general principles are valid, you must consult your own national and local wiring regulations.

Installation of Econet with mains cabling should only be carried out under the supervision of electrically qualified personnel.

If your trunking will contain both Econet and mains cables, you need to use trunking as specified in the BS 7671: Requirements for Electrical Installation (IEE Wiring Regulations) and BS 6701: Installation of Telecommunication Apparatus or equivalent national standards.

These require that either, the circuits are permanently separated within the open trunking by a minimum of 50mm or that the trunking provide a segregated channel for each circuit type. Metallic trunking must be securely earthed as specified by the standards.

Installing mains sockets

You must ensure that the mains and Econet cables continue to be separated if you install a mains or Econet socket within or adjacent to the trunking.

If the socket installation requires the cables to cross over, you must install an extension to the internal barrier. The barrier extension must be large enough to include a generous safety margin to allow for any anticipated cable movement, and it must be earthed if it is metallic.

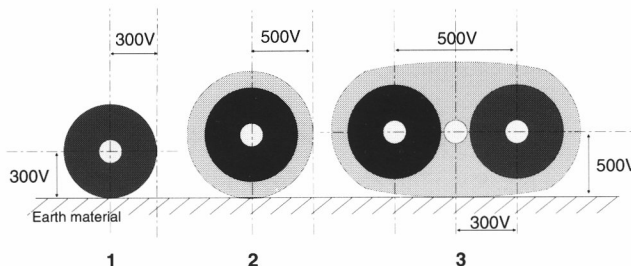

Figure 5.2: Voltage rating of 240VAC cables

The normal single core mains wire covered with a single insulation sheet (1) which is rated at 300V AC. When covered with another layer of insulation (2) or incorporated into a two wire plus earth cable (3), it is rated at 500V AC.

The wiring standards require a test voltage of 500V to be used to verify the installation wiring. The use of single core mains wires adjacent to the Econet cable will not pass the test. Note that when either the double-insulated wire (2) or the cable (3) are stripped back to allow the installation of a mains socket, you are removing protection.

Follow the wiring standards, and make sure that all work is verified by an electrically-qualified engineer before use.

You are advised to use trunking which is designed to accommodate both mains and Econet sockets.

If you mount a mains socket within the trunking in its own compartment, you must again ensure that none of the mains wires are exposed outside of the box to the Econet cable.

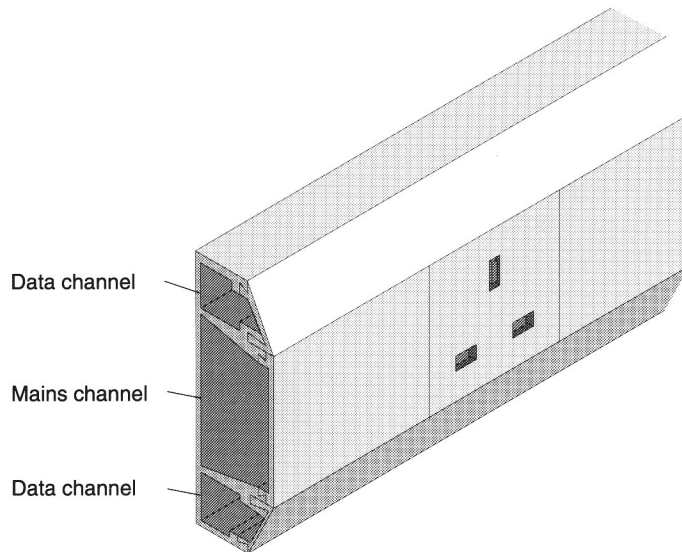

Figure 5.3: Trunking with 2 secondary channels

External cabling

You can use round or flat conduit for sections of the cable which run underground or outside. Conduit is suitable for this purpose because it is unlikely that other cables will need to be passed back through the same conduit. You are advised to fit transient suppressors to the cable because when Econet cable runs from one building to another it is prone to interference from electrical discharge or lightning. For information about this, refer to *Interference on the network* on page 57.

Safety

Many buildings have underfloor or roof voids which are designed to allow for the increasing amount of electrical and telecommunication wiring installed in buildings. The ease with which cable can be run from one area to another can lead to a reduction in safety. The requirements for separation of Econet from mains wiring as outlined in this chapter must be followed.

6 The Econet clock

Why do you need a clock?

Each network segment needs a clock to time the transmission of data across the cable.

Positioning the clock

Ideally the clock should be placed within 30 metres of the middle of the local network. This is because when a pulse leaves the clock, it takes time to reach the network stations. The greatest delay on the network is between one station connected to a network at the same place as the clock and another at the furthest distance from that point.

If the cable runs underground outside a building, the clock should be placed as close as possible to the point where the cable enters or leaves the building. If the clock can only be positioned at the end of the network, one side of the clock should be plugged into the cable and the other side plugged directly into a terminator as shown in *Figure 6.1: Clock position on Econet networks*.

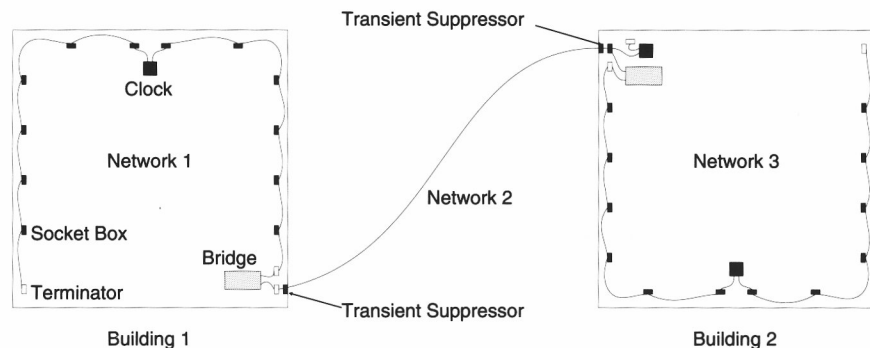

Figure 6.1: Clock position on Econet networks

While the network will work perfectly reliably with the clock at one end, the delay is twice what it would be with the clock in the centre. On a long network this substantially reduces the maximum data rate.

Econet clocks

This section covers Acorn and SJ Research clocks, as both of these have been supplied in Acorn Econet Starter Kits. Third parties have also produced clocks for use with Econet; users of these clocks should refer to the documentation supplied with their clock.

Acorn clocks

There have been two basic types of Acorn clocks used on Econet systems, the Level 1 Clock and the Level 3 Clock (names based on the name of the Econet file server used at the time of introduction).

- The Level 1 Clock is in a grey and light grey case with a single 5-pin DIN socket.
- The Level 3 Clock is in a black case and has two 5-pin DIN sockets.

FileStore also has the ability to generate a clock signal for the network and can be considered as a Level 3 clock.

The Acorn Level 1 clock

The Level 1 Clock is a symmetrical clock. This means that the clock signal spends the same amount of time high as it does low as shown in *Figure 6.2: The output waveform of a symmetrical clock*.

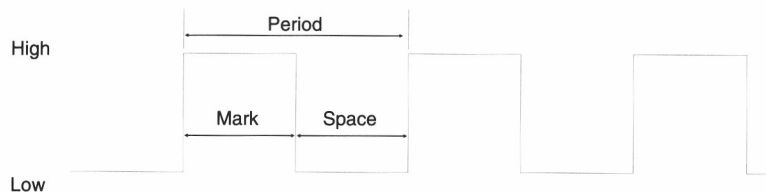

Figure 6.2: The output waveform of a symmetrical clock

Users of the Level 1 clock are advised to upgrade to the Level 3 clock.

The Acorn Level 3 clock

The Level 3 Clock is an asymmetrical clock. This means that the clock spends unequal periods of time high and low as shown in *Figure 6.3: The output waveform of an asymmetrical clock*.

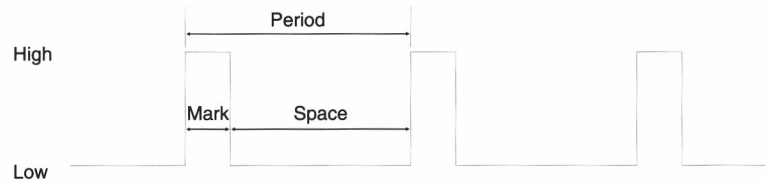

Figure 6.3: The output waveform of an asymmetrical clock

The Level 3 asymmetrical clock gives more reliable data transfer on a network, as it allows the 68B54 IC in the network interface to operate at its optimum level. The asymmetrical clock can be adjusted to produce a symmetrical output, the Level 1 symmetrical clock, however, cannot produce an asymmetrical output.

There are a number of types of asymmetrical clock available, the Acorn external clock, the FileStore internal clock and the SJ Research clock are the most common. The difference between the Acorn and SJ Research clocks lies in the amount of fine tuning which can be applied to the clock signals.

Setting the clock speed

When dealing with clocks, you should bear in mind that

- the faster the clock, the faster the data transfer
- long networks require slower clock speeds
- poor quality cable requires slow clock speeds.

The clock pulse is made up of two parts; the **mark** and the **space**. The mark and the space combined make the **period**, and determine the frequency at which the clock operates.

The mark and space can be adjusted by changing links in the clock. If the clock speed and/or the mark space ratio are set incorrectly, communication between the computers may fail.

Data transfer takes place on the leading and trailing edges of the clock pulses, transmission takes place on the clock + falling edge and before the clock + rising edge, the data is sent down the data + and data - cables so that it coincides with the appropriate clock pulse. The propagation of these signals is affected by the

length and quality of the installation; if the clock speed is not matched to the installation the data may arrive at the wrong time, preventing successful communication.

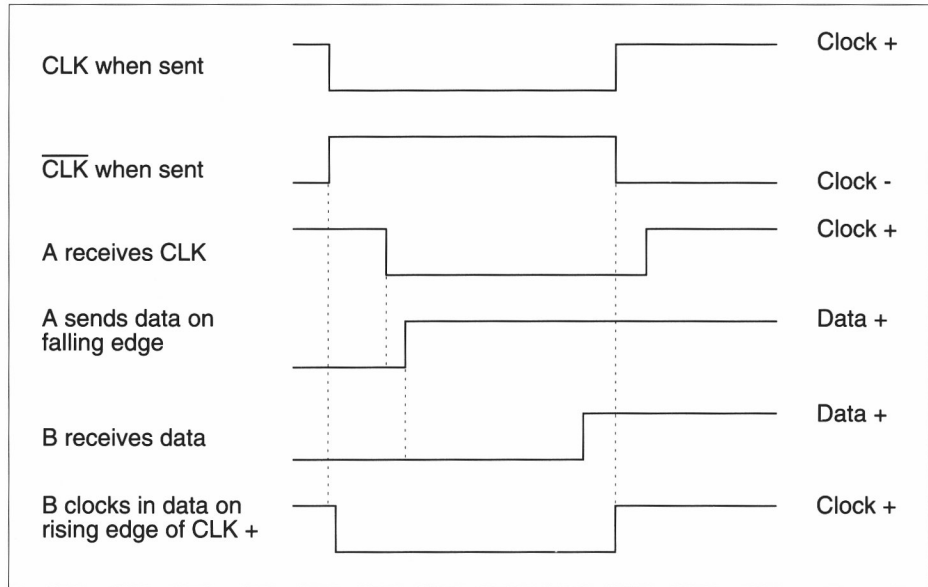

To change the clock speed you need to change a number of links or switches inside the clock unit. *Figure 6.4: The Acorn clock link positions* shows the position of the links for the current Acorn clock design.

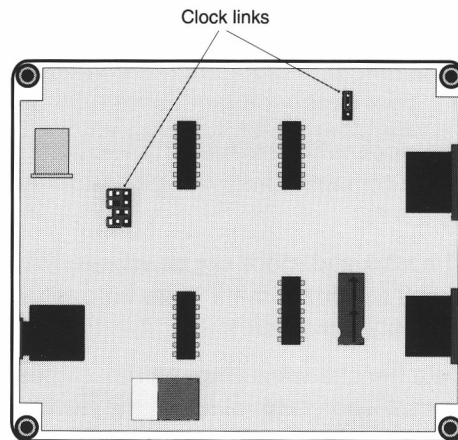

Figure 6.4: The Acorn clock link positions

The Acorn clock default setting is:

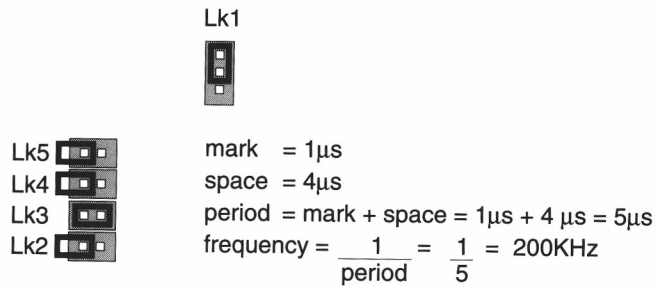

Figure 6.5: The Acorn clock default link settings

In the SJ Research clock the links are in the form of Dual In Line (DIL) switches as shown in Figure 6.6: The SJ Research clock DIL switch positions.

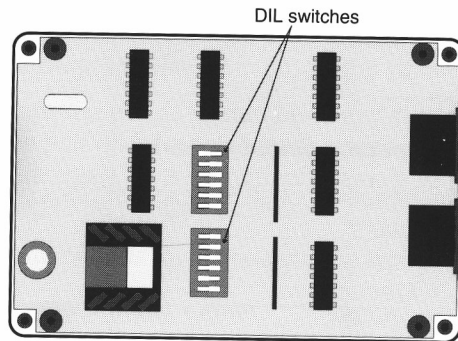

Figure 6.6: The SJ Research clock DIL switch positions

The SJ Research clock default setting is:

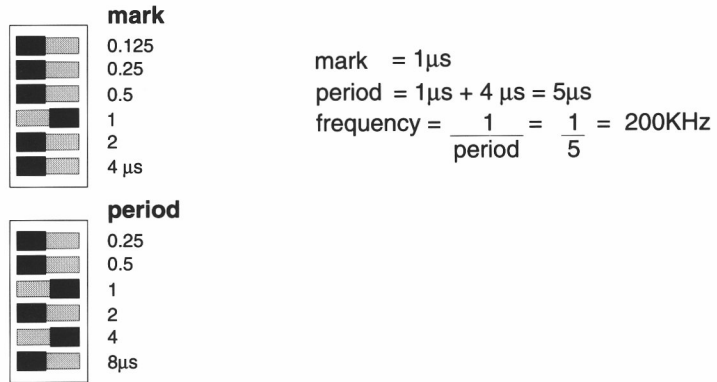

Figure 6.7: The SJ Research clock default DIL switch settings

Some early SJ Research clocks had the Mark switches incorrectly labelled Space. The switches have the same function on all SJ Research clocks; the switches directly adjust the mark, and the space is controlled by the mark and period settings:

$$\text{space} = \text{period} - \text{mark}$$

The frequency of an SJ Research clock can be calculated using the following formula:

$$\text{Frequency} = \frac{1}{\text{mark} + (\text{period} - \text{mark})} = \frac{1}{1 + (5 - 1)} = 200\text{KHz}$$

You can see that the value assigned to the mark can be changed without altering the frequency. For example, if you were to change the value of the mark, by extending the time the clock spends high to 1.25 μs, the frequency would remain the same:

$$\text{Frequency} = \frac{1}{\text{mark} + (\text{period} - \text{mark})} = \frac{1}{1.25 + (5 - 1.25)} = 200\text{KHz}$$

It is the ability to change the proportions of the mark and space, without changing the overall frequency, which differentiates the Acorn and SJ Research clocks and allows the SJ Research clock to be appropriately fine-tuned to a network. This type of fine tuning is very important if the network is to operate reliably at a given frequency. To appreciate this it is necessary to understand how data is transmitted and received by two stations on the network.

How data is transmitted and received

Data transfer takes place on the leading and trailing edges of the clock pulses, transmission takes place on the clock + falling edge and before the clock + rising edge, in other words, in the time frame set by the value of the space. The time taken to transmit data from one station and be received by the another must not exceed the time set by the value of the space, otherwise the data sent between the two stations will be lost.

The best clock setting for a particular network is determined by three factors:

- The period must be long enough for the slowest station. This is usually the main consideration on a short network. The safe value for all current station types is 5 μ s.
- The mark must be long enough to ensure reliable reception of the clock at all stations. Most networks will work with a mark of 1 μ s although this depends on the quality of cable and installation (multiple junctions and branches or poor quality cable will require a longer mark for reliable operation.)
- The space must allow sufficient time for the data to travel along the network from one station to another. (The default value is usually suitable.)

Within these constraints, the period should be as low as possible (to achieve the fastest data rate). Note that on long networks the period will be governed by the mark plus the minimum space for the length of network, so reducing the mark will usually allow the period to be reduced as well.

The suggested minimum periods for various station types are:

RISC OS-based stations	2.00 μ s
Econet bridge	3.00 μ s
SJ Research file servers	3.00 μ s
FileStore	4.00 μ s
BBC / Master (without 2nd processor)	4.00 μ s
BBC / Master with 2nd processor	5.00 μ s

The period must not be more than 13 μ s, as this may cause intermittent no clock errors. If the network is too long to fit within this limit, it must be sub-divided into smaller network segments, connected by bridges.

Calculating the minimum mark and space values

From the description of the way data is transmitted on a network you can see that the mark setting represents wasted time. The mark exists solely so that the network hardware can recognise a clock signal.

The longer the network, the longer the mark setting must be, because the mark pulse gets distorted. The most appropriate mark value cannot be calculated exactly, so it has to be determined by trial and error. You can, however, calculate the theoretical value of the mark and space as a starting point.

Calculating the space value

The space must be long enough to allow sufficient time for the data to travel from one station to another. This varies according to the distance between the stations, and the speed at which the signals travel along the cable. The space must allow for the worst delay between any combination of stations; if the space is too short, some stations will not be able to communicate reliably (for example, all stations may be able to communicate with the file server but stations at opposite ends of the network may not be able to communicate with each other).

You also need to consider the delay between a clock pulse leaving the clock and arriving at the stations. The greatest difference is between one station connected to a network at the same place as the clock and another at the furthest distance from that point.

When calculating the space value, you have to allow time for the clock pulse to travel to the distant station, and then time for the data pulse to travel back to the computer near the clock. (The small delay travelling through the circuits inside the computer may be ignored.)

The space value is therefore twice the time taken for signals to travel from the clock to the station:

$$S = \frac{2 \times d}{v \times c}$$

where:

d = distance in metres

v = velocity factor of the cable; the speed at which pulses travel along the cable expressed as a fraction of the speed of light

c = speed of light; a constant 300,000,000 (3×10^8) metres per second

Consider a network consisting of 500 metres of cable, where the clock could not be put in the centre of the cable, but is 200m from one end and 300m from the other. The network has a number of BBC micros, one with 6502 second processor, and an SJ Research file server.

- The minimum velocity factor for the recommended cables is 50%, so $v = 0.50$
- The distance from the clock to the furthest station is 300m, so $d = 300$

The space value is therefore:

$$S = \frac{2 \times 300}{0.5 \times 3 \times 10^8} = 4 \mu s$$

This is a minimum value, so you choose the next largest convenient setting, in this case $5 \mu s$. If this value proved to operate reliably you could set the space to $4 \mu s$, but you would have to monitor the networks performance closely in case this proved to be unsuitable.

Setting the mark and period

You must now select a mark value, and as the cable is quite long we take a safe value of $1 \mu s$. The settings are therefore:

mark = $1 \mu s$

space = $5 \mu s$

period = $6 \mu s$ frequency = 166 KHz

Finally, you must make sure that the period is large enough for the slowest type of station, but not too large for reliable clock detection. The BBC with 6502 second processor is the slowest machine at $5 \mu s$. The maximum for all stations is $13 \mu s$, so $6 \mu s$ would be a satisfactory value.

The following table illustrates the various mark and space settings, with the appropriate frequency, available to users of the Acorn clock.

Link2	Link3	Link4	Link5	Link1 1µs	Link1 2µs	Mark/Space Ratio
Open	Open	Open	Closed	500kHz	250kHz	1:1
Open	Open	Closed	Open	333kHz	167kHz	1:2
Open	Open	Closed	Closed	250kHz	125kHz	1:3
¹ Open	Closed	Open	Open	200kHz	100kHz	1:4
Open	Closed	Open	Closed	167kHz	83kHz	1:5
Open	Closed	Closed	Open	143kHz	72kHz	1:6
Open	Closed	Closed	Closed	125kHz	63kHz	1:7
Closed	Open	Open	Open	111kHz	56kHz	1:8
Closed	Open	Open	Closed	100kHz	50kHz	1:9
Closed	Open	Closed	Open	91kHz	45kHz	1:10
Closed	Open	Closed	Closed	83kHz	42kHz	1:11
Closed	Closed	Open	Open	77kHz	38kHz	1:12
Closed	Closed	Open	Closed	71kHz	36kHz	1:13
Closed	Closed	Closed	Open	67kHz	33kHz	1:14
Closed	Closed	Closed	Closed	63kHz	31kHz	1:15

¹ = default Acorn clock settings

Setting the clock speed

All Acorn clocks are factory set to a speed of 200kHz. This is the maximum speed of operation for mixed machine networks up to 500m. Acorn do not recommend networks segment lengths above 500m.

SJ Research cable is designed to operate with networks up to 1200m in length, however, the viability of such a long network is dependant upon external factors such as the number of joins in the cable, the clock position, the number of soldered connections, etc. Before installing a network of this length you should seek advice from Acorn or SJ Research.

You can use your calculated value as the starting point for setting an appropriate clock speed. There are two ways of establishing the correct clock setting for a particular network:

- trial and error
- use of the NETMON program.

The NETMON program establishes when data transfer begins to fail but is not currently available on networks of RISC OS-based machines.

Setting the clock by trial and error

You will have to use this method if you have a network of RISC OS machines.

Set the clock to the theoretical speed you have established.

Next, try to `*Dump` a program of significant length, such as `$.Utils.Copyfiles`, from the station positioned next to the terminator and with the file server at or beyond the clock. (Alternatively, create a large file, for example `*SAVE junk 0+F000`, and use `*DUMP filename` to view it.

Then, with all the other stations inactive, type:

```
*DUMP junk
```

The output should flow smoothly up the screen, with only brief pauses when the file server has to read the disc. If the output comes out with large pauses, the network is not working properly.

Repeat this test on several stations at different locations on the network. If the file fails to load you should slow the clock down by one setting and try to load the file again.

Continue testing until reliable communication is obtained, and then set the clock one setting slower to allow a safety margin to help ensure that the network functions correctly under all operational conditions.

Setting the clock using NETMON

NETMON is a NETWORK MONitor program which establishes when data transfer begins to fail; when stations are unable to correctly complete the four-way handshake.

There are two versions of NETMON supplied with current Acorn file servers, one for the BBC Model B which is stored in the `Library`, and one for the BBC Master 128 and BBC Master Compact which is stored in `Library1`. NETMON is not currently available on networks of RISC OS based machines.

The program is run by typing the following commands:

To run NETMON on a BBC Model B machine, type:

```
*Run $.Library.NETMON
```

To run NETMON on a BBC Master 128 or BBC Master Compact, type:

```
*Run $.Library1.NETMON
```

Make sure that nobody else is using the network and then log on to the file server from the machine at the furthest end of the network.

*Dump a program of significant length, such as \$.Utils.Copyfiles. Alternatively, create a large file (for example *SAVE junk 0+F000) and use *DUMP filename to view it.

Then, with all the other stations inactive, type:

```
*DUMP junk
```

You can control the output from NETMON using *Ctrl-Shift*.

A normal data transfer looks like this:

```
FE00BD0080v99 BD00FEv00 FE00BD00900001020444454C455445v0D BD00FEv00 i
BD00FE0080v90 FE00BDv00 BD00FE0000v00 FE00BDv00 i
```

The lower case characters which appear towards the end of each block of data indicate how the network is running.

The lower case *v* in the above example indicates that everything's OK. However, the lower case *b* in the following example indicates the network is running too fast.

```
C800010080b i
```

The next example indicates that a machine has tried to locate a file server, but has received no acknowledgement of its existence

```
FE00120080v99 i.
```

Slow the clock down and repeat the loading of the file and look for occurrences of lower case *b* at the end of the blocks of data. Repeat this until you obtain no further occurrences in the NETMON output.

A more complete description of the data blocks given above can be found in *Appendix C: About NETMON*.

The FileStore Clock

The FileStore can generate a clock signal if it detects no clock presence on the network. However, use of the FileStore clock is not recommended in preference to an external clock because the FileStore is unable to generate voltages of the same rating as an external clock, so on long networks there may be insufficient voltage to drive the network adequately.

Switching on the external clock when you have a FileStore

You must switch the FileStore and separate clock in the right order; first switch on the external clock, then switch on the FileStore.

If you switch on the FileStore first, it detects that no clock is present and generates its own clock. When you then switch on the external clock, it produces a clock signal which clashes with the FileStore clock. When two clock signals are present on the same network an error message, such as `Station xxx not present`, `Not listening` or `No reply from station xxx`, is given. To cure the problem, restart the FileStore.

The FileStore may still fail to detect the presence of a clock signal on the network. This may be due to a number of factors, such as the speed of the main clock, poor quality cable etc. If your FileStore fails to detect an external clock, you should disable the FileStore's internal clock.

Disabling the FileStore clock

If the clock detection circuitry develops a fault, this can have a major impact on network performance. Disabling the clock usually solves most problems, but if you encounter further problems you are advised to seek a repair.

You disable the FileStore clock simply by removing all the links which set the clock speed. To gain access to these links you must remove the casing.



This adjustment must only be carried out by a technically-competent person who observes all due precautions. Parts of the exposed wiring and components will have hazardous voltages present when energised.

Before attempting to remove the casing of the FileStore, switch off the FileStore, and remove the power lead from the mains socket.

- 1 When you have switched off the FileStore and disconnected it from the mains, unclip the front and rear mouldings.
- 2 Unclip the side mouldings.
- 3 Remove the four screws holding the top metal wrap to the unit and slide it off backwards.

Figure 6.8: Position of the clock speed links on the FileStore E01 main PCB shows the position of the clock speed links on the main PCB of the FileStore E01.

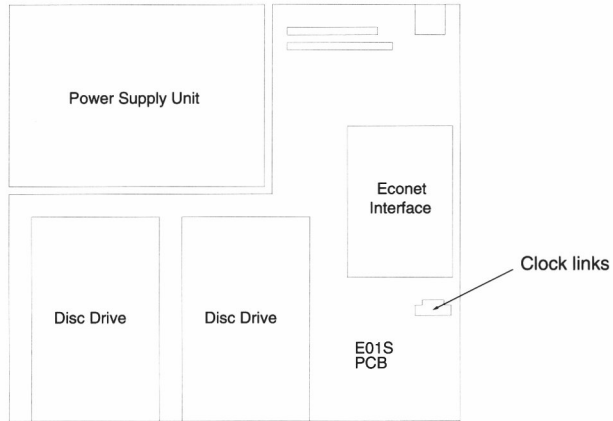

Figure 6.8: Position of the clock speed links on the FileStore E01 main PCB

Figure 6.9: Position of the clock speed links on the FileStore E01S main PCB shows the position of the clock speed links on the main PCB of the FileStore E01S.

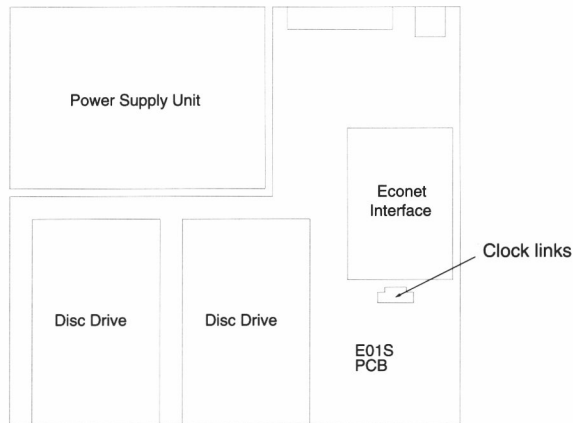

Figure 6.9: Position of the clock speed links on the FileStore E01S main PCB

The links settings for both these FileStores are determined in the same way as for an external clock. *Figure 6.10: The default clock link settings for the FileStore E01 and E01S* shows the default setting and meaning of each link.

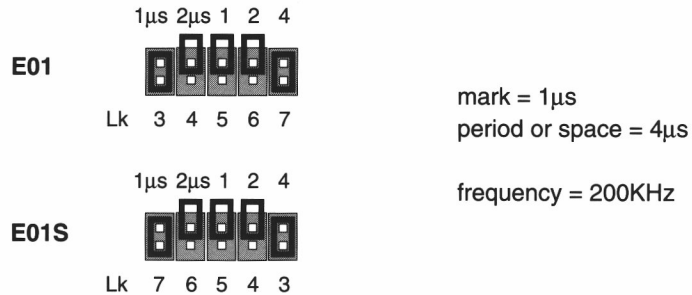

Figure 6.10: The default clock link settings for the FileStore E01 and E01S

- 4 Disable the internal clock of either FileStores by removing both end links, 3 and 7.
- 5 Reassemble the unit.

The Level 1 clock

This section is included for reference only. Acorn strongly recommends the replacement of any clock which predates the Level 3 clock.

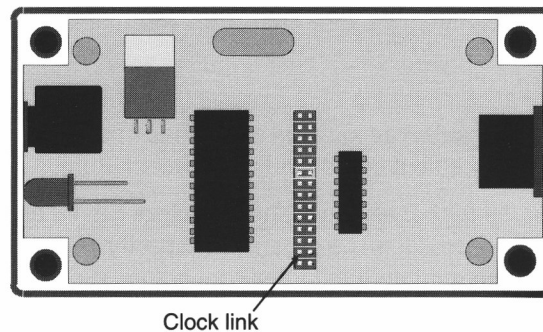

Figure 6.11: Position of the clock link in an Acorn Level 1 Clock

The default link setting for the Level 1 clock:

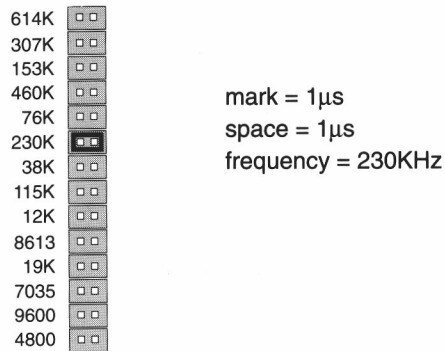

Figure 6.12: The default clock link setting for the Acorn Level 1 clock

The Interlock

The Interlock is an Econet interface which incorporates the clock and terminator functions. The Interlock is manufactured by XOB (see *Appendix I: Useful addresses*).

You can use the Interlock simply as an Econet interface, or you can configure it to be an Econet clock and/or a terminator as well.

The Interlock is only suitable for short networks and is subject to the same restrictions as the FileStore's internal clock when used to provide the clock for the network.

If you are considering using the Interlock as a clock/terminator, you must always consider the location of the machine containing the clock or terminators; incorrect placement could lead to network failure.

Note that although the Interlock can be used in A3020 and A4000 machines, its use restricts the expansion capacity of the machine as, when installed, it obscures the mini podule Molex connectors. (See *Appendix G: Econet interface options for the A3020 and A4000* for details on the use of older Econet interfaces with these machines.)

The board layout of an Interlock and the Acorn Econet interface designs are shown below.

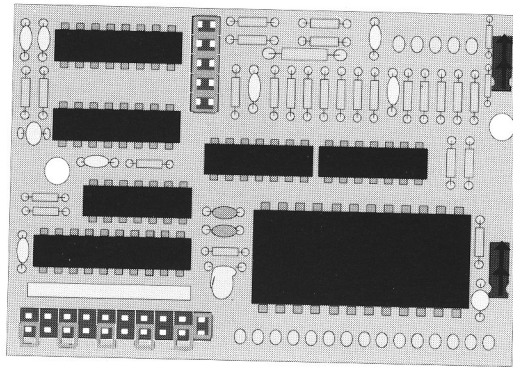

Figure 6.13: The Interlock Econet interface

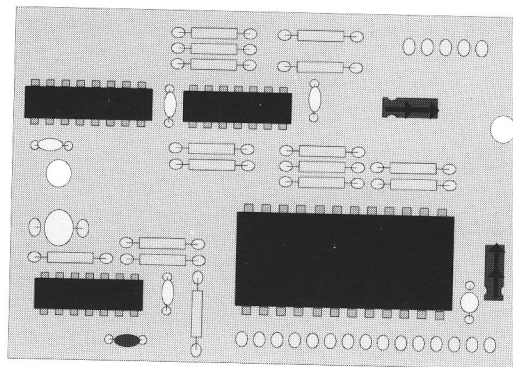

Figure 6.14: Obsolete Acorn Econet interface which does not contain collision detect circuitry

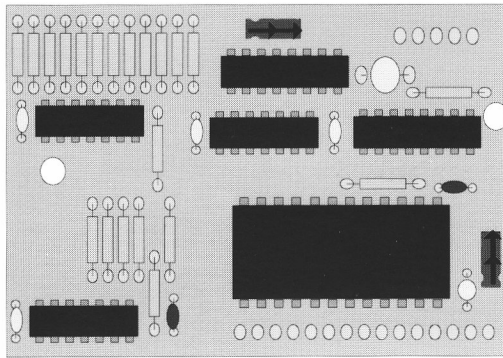

Figure 6.15: Acorn Econet interface ADF10 which contains collision detect circuitry

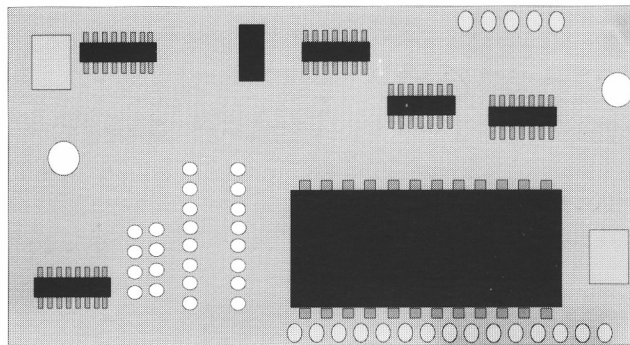

Figure 6.16: Acorn Econet interface AEH52 for the A3020 and A4000

7

Terminators

Why terminate a network?

A network needs to be correctly terminated in order to function correctly. Terminators prevent signal reflections travelling back down the cabling, and provide the voltage bias on the Data + and Data - lines in order to allow detection of the line idle condition.

There are two types of terminator, active and passive. Active terminators are powered externally; passive terminators require no external power source.

Active terminators are no longer available as they have been superseded by passive terminators. It is recommended that you replace active terminators on your network with passive terminators.

Passive terminators

Both Acorn and SJ Research produce passive terminators

Acorn terminators are housed in small black plastic boxes and consist of an impedance matching circuit and a solderless connector for the cable. The appearance of an Acorn terminator differs from that of an Acorn socket box only in that it has just one 5-pin DIN socket.

Acorn terminators

- cannot be switched off
- cannot be removed
- allow easy identification of ends of the network
- cannot be easily stolen.

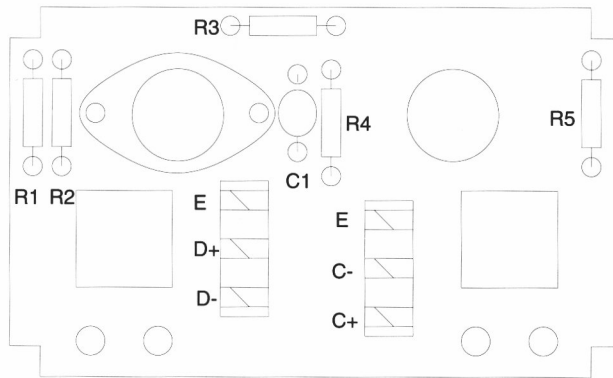

Figure 7.1: The layout of the Acorn terminator PCB

SJ Research terminators are built into a 5-pin DIN plug and are supplied with the clock. These terminators are simply inserted into each socket box which marks the end of the network.

In certain environments, schools in particular, SJ Research terminators are prone to theft. To overcome this problem, the SJ Research installation kit contains a pair of secure terminators which prevent removal of the terminators. SJ Research terminators can be easily removed and repositioned, if the network is extended.

SJ Research terminators are very useful if a fault develops, because you can cut the cable and move the terminators, thereby enabling you to cut off the suspect part but retain the use of the remainder of the network.

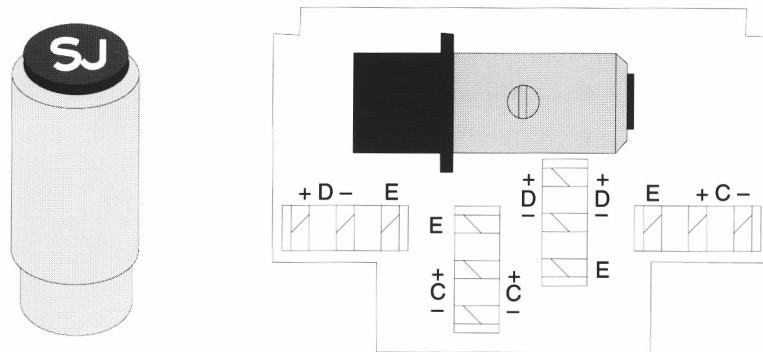

Figure 7.2: The SJ terminator and the SJ secure terminator PCB (with the terminator fitted).

Active terminators

Active terminators are used only with the Level 1 symmetrical clock. You are advised to update your network to use the current asymmetrical clock and passive terminators to improve the performance and reliability of your network.

An Acorn Level 1 Terminator is shown here for reference.

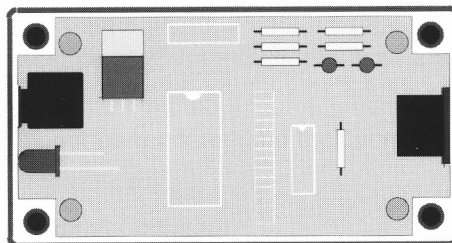

Figure 7.3: The Acorn Level 1 terminator

The FileStore

It is possible, although not recommended, to use the FileStore to provide limited termination on a small network. You are advised only to use FileStore termination for single machine access, on a cable length of not more than 6m.

Networks which use the FileStore internal clock do not usually have external terminators fitted (because Acorn terminators are available only with the Network Starter Kit, which contains an external clock).

The FileStore's internal termination terminates the network only once. This termination is somewhere along the length of the cable instead of at both ends. If your cable is too long, reflections in the cable will prevent correct operation.

Why terminate a network?

8

Socket boxes

This chapter describes some of the types of socket box you may use when you install an Econet network.

You are advised to seek professional assistance from your local network supply agency when installing socket boxes.

When connecting Econet socket boxes and the Econet cable:

- always use the correct cable
- do not cut the cable unnecessarily
- never strip the insulation off the cable
- do not use sockets which require making soldered connections directly between the Econet cable and the DIN socket or PCB
- ensure any connections are gas tight to prevent oxidation
- never mix the single wires from each pair
- always use the correct tools for the job.

Econet socket boxes

A number of different 5-pin DIN socket configurations have been used since Econet was introduced

- Acorn socket boxes which utilise a pair of Insulation Displacement Connectors (IDCs) for making the connection between the cable and sockets
- SJ Research socket boxes which utilise two pairs of IDCs, which are more suitable if the cable has been cut.
- Digital Services solderless crimp outlets which use grease-filled crimp connectors
- soldered fascia panel mounted sockets.

Socket box failure

Socket box failure is usually indicated by intermittent or variable socket behaviour leading to complete failure.

There are a number of reasons for socket failure, and these include poor soldering, failure to insulate the soldered joints, and breakage of the cable at the joint due to the lack of cable support.

Networks which contain soldered facia panel mounted sockets are generally more prone to failure.

Insulation Displacement Connectors

IDCs are not designed to take two wires per connector, where the core of the wire exceeds 0.63mm **or** where the outside diameter exceeds 1.5mm. Cable which meets the specification for Econet exceeds **both** of these parameters. Consequently Econet cable should not be cut at each socket box (when using Acorn socket boxes) as both ends of the wire cannot be inserted in the same IDC. This specification of cable also prevents the re-use of a socket box once it has had wires inserted into the IDC.

Acorn socket boxes

Acorn socket boxes have the following characteristics:

- Connection to IDC prevents oxidation of the connections
- Cable can be used in continuous lengths giving reliability and ensuring that if one socket fails, the others continue to operate
- The cable is supported with cable ties, preventing stress being placed on the connections
- The connection between the cable and IDC will be unreliable if the cable is cut as both ends of the cable are inserted into the same IDC.

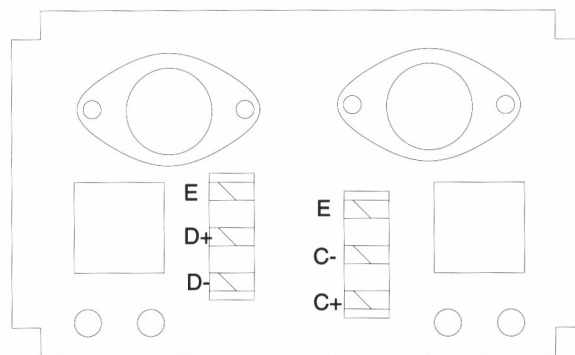

Figure 8.1: The PCB layout of an Acorn socket box

SJ Research socket boxes

SJ Research socket boxes have the following characteristics:

- Connection to IDC prevents oxidation of the connections
- Cable can be used in continuous lengths giving reliability and ensuring that if one socket fails, the others continue to operate
- The socket boxes remain reliable if the cable is cut as there are duplicate IDCs allowing a cut cable to be correctly connected to the sockets.

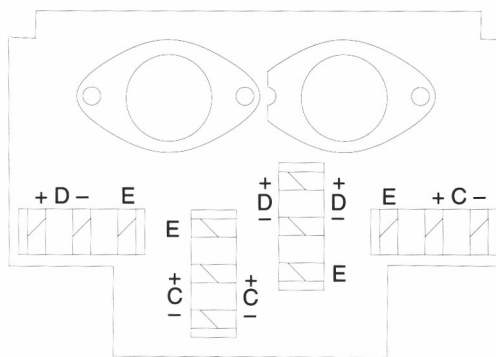

Figure 8.2: The PCB of an SJ Research socket box

Soldered 5-pin DIN sockets

Soldered 5-pin DIN sockets have the following characteristics:

- Connections are prone to failure due to contact with the air causing oxidation
- Poor soldering can result in dry joints
- The cable is held by a solid joint, with no additional support from a cable tie, which makes it prone to breakage due to the weight of the cable; the failure of one joint may render the network unusable
- The cable has to be cut at each socket in order to make the necessary connections to the 5-pin DIN socket.

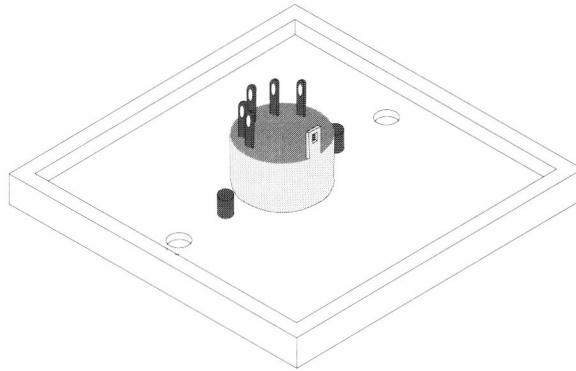

Figure 8.1 A solder type 5 pin DIN socket and facia panel

Digital Services solderless crimp outlets

In some circumstances the use of the recommended twin socket boxes is not possible, for instance where an Econet socket is already provided as standard on commercial trunking systems.

An acceptable alternative in such cases is the use of Digital Services solderless crimp outlets.

The sockets themselves are prepared away from the network and consist of a single or pair of 5 pin 180 degree DIN sockets. They are wired according to the specification used in the installation, soldered onto the tags of the DIN socket, and covered with either heat shrink or neoprene sleeving:

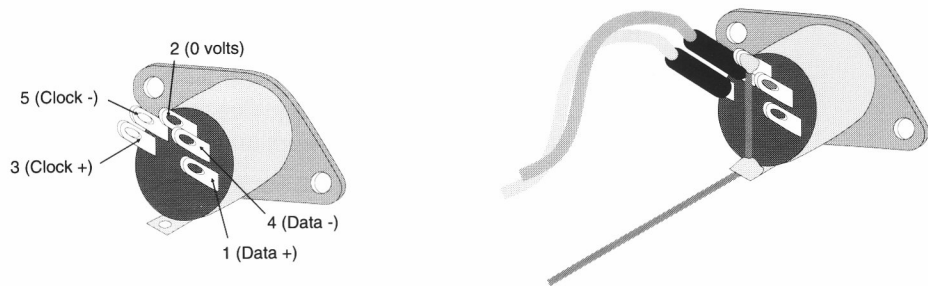

The outer insulation is removed from the main Econet cable in exactly the same manner as if fitting a standard Econet twin socket box.

The connection between the cable and the flying leads of the socket is made using small grease filled Scotchlok™ connectors (3M part number UG BRIDGE). (Available from Farnell Electronics, order code 143-076).

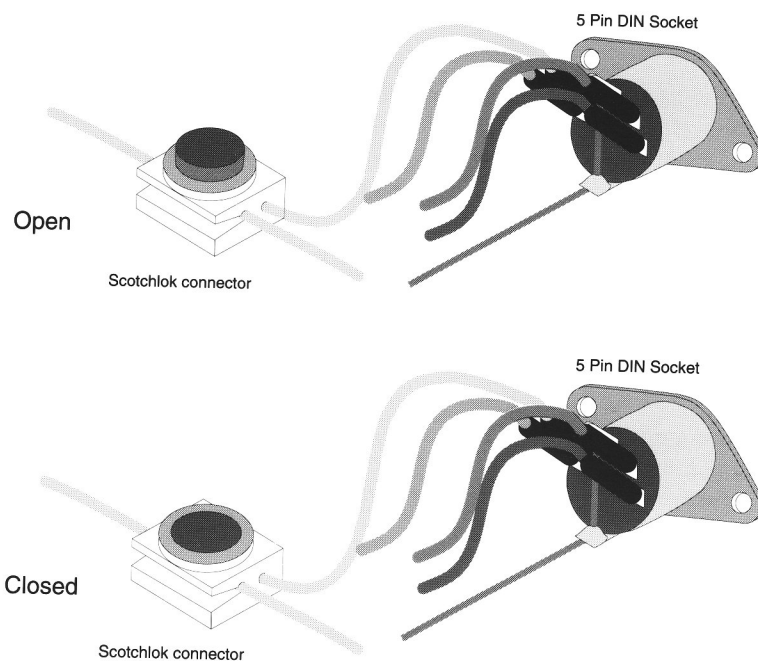

Figure 8.2: Connecting a Scotchlok connector to the flying lead of a pre-soldered Econet socket
The individual socket or completed facia panel can then be simply fitted in place.

9 Interference on the network

Interference on the network can take the form of occasional data errors leading to a series of re-tries or it can be serious enough to cause damage to the equipment. Both the Econet system and the mains system can be subject to interference, so one defective machine or wiring fault can cause problems throughout the system.

The major sources of damaging interference are externally induced pulses such as thunderstorms, and the electrical supply system. Damage may also be caused by static (see the chapter *Installation considerations* on page 17).

The Econet interface

The Econet interface is designed to operate with applied voltages which are never significantly above or below earth voltage. It will withstand short overloads, but the amount of energy which can be absorbed is small and if this is exceeded then the line driver chips will fail.

Why do line drivers fail?

Line driver chips can be damaged by mains supply earthing problems, by externally generated pulses (usually caused by thunderstorms) travelling along the network cable or by excessive levels of mains-borne interference.

Interference entering through the Econet socket is normally dissipated by large value resistors which are present to protect the interface. However, the line driver chip has to supply the maximum possible current in order to achieve high power output across the network. This means that it needs a direct connection to the network wires. It is this connection to the outside world which makes it particularly vulnerable.

The line driver chip can tolerate a short-circuit of its output, either to earth, or to the output of another chip, but an applied voltage above +12 volts, or below earth potential is too much.

Some protection exists in the form of diodes on the chip which prevent the voltage on the pins falling below earth potential, however all the energy entering the machine is dissipated as heat in a small area of the chip, and if the overload is severe, or a small overload persists for any length of time, that part of the chip will melt.

Each line driver chip has two independent halves (for the two data lines in the cable), and overloads tend to damage individual transistors, rather than the whole chip. It is therefore possible for half blown chips to continue to work, but with reduced performance.

Damaged chips are either open circuit, so that no connection is made to the network (only the station with the damaged chip is affected), or short circuit, permanently transmitting onto the network and disrupting all users. Since a different part of the chip comes into play when the station is switched off, it is possible to have faulty chips which work perfectly while the machine is switched on, but jam the network when it is switched off, or vice-versa.

Earthing problems

Most electronic equipment uses a switch mode power supply unit (PSU) in preference to a conventional transformer. The switch mode PSU chops the incoming mains sine wave into a series of pulses, and then uses the energy produced to provide the required equipment voltages. The electrical noise spikes created are filtered out by the PSU, and fed down to the PSU's earth connection which is tied through the mains lead and the building wiring to the distribution board earth connection. This in turn ties the incoming supply earth to an earth pin driven into the ground.

In a normal system, all earthed equipment has earthed components operating at roughly the same potential with reference to the supply earth (around zero volts). If the earth potential at one station is significantly above or below that at other stations, current will flow from one earth to the other, through the line driver chips in the respective machines.

What causes earthing problems?

The most common cause of earthing problems is the earth pin on a mains socket becoming disconnected from the supply earth. If this happens, the electrical noise spikes from the PSU are not held at the supply earth potential but float to a value which may be as high as 60 volts AC.

If an affected machine has been used without a network connection and is then connected to the network, the network earth will attempt to substitute for the normal earthing system to bring it back into line, but not before the 60V has had time to damage a few line drivers. If there are several such machines, the network earth will not be able to cope with the leakage currents and there will be a permanent potential difference, causing the network to behave unreliably and to blow line drivers on a regular basis.

Faulty appliances can also cause occasional earthing problems; a fault shorting live to earth causes large currents to flow in the earth wiring until the fuse blows. This causes the local earth potential to increase during the period that the fault current is flowing, again causing problems.

Networks between buildings

Separate buildings (or buildings with more than one independent electrical supply system) do not have a direct connection between their earths, other than via the network cable.

Electrical supply systems have earth electrodes driven into the ground, and providing these are in good condition and the soil has not dried out, the earth potentials will be close enough for the network to operate without trouble. Occasionally, however, due to a faulty appliance being connected, or simply switch-on surges in large plant (such as kettles, photocopiers, lathes etc.), the earth potential will take a temporary jump, causing damage to line drivers unless precautions have been taken.



You should not work on any installation to link buildings while there is any likelihood of an inter-building section of the cable being struck by lightning.

Thunderstorms

You would not expect the network to survive a direct lightning strike, but it would be useful if it could tolerate a bolt of lightning landing nearby.

When lightning strikes, a huge electrical current (many thousands of amps) enters the ground in a small area. This has two effects; a strong magnetic field is produced, inducing currents in any nearby conductors (such as the Econet cable), and earth potential differences are created in the soil; as the current spreads out into the earth, buildings near the point of the lightning strike will measure a different earth potential to those further away.

Significant voltages appear at the end of the cable, measured with respect to the local earth, and a current flows from the earth in one building, through the line drivers in local stations, down the cable, in through the line drivers of machines in the second building and away to that earth.

Lightning problems generally only affect sites with more than one building; the wiring in a single building is not usually laid out in such a way as to couple the magnetic flux, and a single building will generally be at a fairly consistent earth potential. However large runs of Econet cable on the outside of the building or in the roof space should be avoided if possible as these have a greater chance of being affected.

Transient suppressors

Transient suppressors prevent noise pulses travelling past them, so preventing damage to line drivers.

A transient suppressor clamps each of the signal lines within a permitted range from its earth connection. Therefore a low impedance connection to earth is essential. (Consult the installation notes supplied with the transient suppressor for further details.) If the earth potential at a transient suppressor is the same as that at a nearby station, the voltages applied to that station will never be high enough to damage it.

Surge voltages travel as pulses along the cable at the same speed as other signals. If the pulse reaches a station before it reaches a transient suppressor, that machine will be damaged. You should therefore install transient suppressors between likely sources of interference and the machines that they are to protect; this usually results in transient suppressors being installed at the point at which the network cable enters the building:

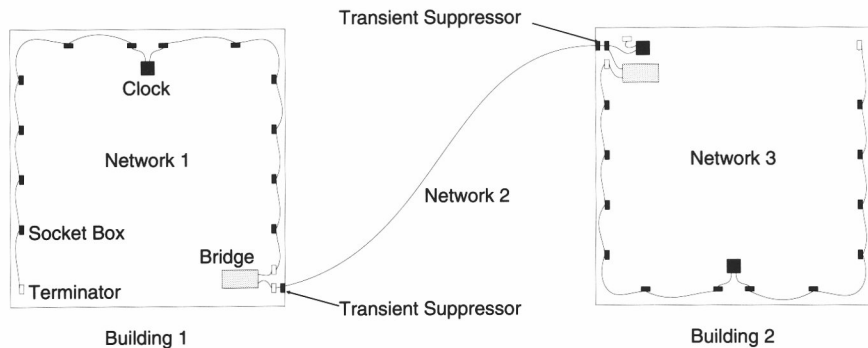

Figure 9.1: The position of transient suppressors on a network linking two buildings.

How do transient suppressors work?

Each make of transient suppressor varies in the way it works. Inside an SJ Research transient suppressor box, there are four suppressor diodes connecting between each of the network clock and data lines and ground.

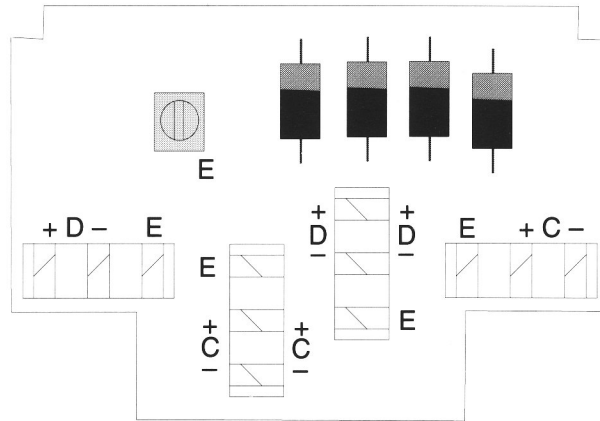

Figure 9.2: Inside an SJ Research transient suppressor box

Under normal conditions, very little current flows through the diodes, but as soon as the voltage across the diodes exceeds specification, the diodes conduct and clamp the voltage to a safe level.

The suppressor diodes are similar to conventional zener diodes, but have a much greater capacity to suppress energy. For example, the diodes used in SJ Research transient suppressor boxes (or Zap boxes) can keep the voltage below 13V when a current of up to 130A is flowing. They can suppress 1kW of power for up to 5 minutes, and even higher power levels for shorter periods.

If the energy in the surge exceeds the capacity of the diodes, they are designed to fail to a short circuit; damaging themselves, but continuing to protect the computers. A normal zener diode will fail at very much lower energy levels, and will probably fail open-circuit, leaving the remainder of the surge energy to dissipate itself in the computers.

Mains-borne interference

All Acorn mains-powered equipment is designed to be able to operate with less than perfect mains supplies but this immunity is limited by both the frequency of the occurrence and the magnitude of the mains supply disturbance.

Mains-borne interference can be generated by electrical distribution system switching, thunderstorms, defective apparatus, and so on.

If you suspect that the supply for your network is suffering from poor mains, you should consult a qualified electrician. These are some of the problems that can occur:

- High and low average value
- Sags and surges
- Spikes
- Dropouts
- Power cuts
- High and low frequency
- High frequency noise.

High and low value

Low volts problems are likely to be found in rural areas supplied via long power lines, while high volts may be found near substations and generating plant. A high average tends to overheat the equipment and thus reduces its long term reliability, whilst a low average reduces the equipment's ability to deal with other disturbances and thus increases the likelihood of erratic operation.

Sags and surges

These are short term disturbances which occur for **less** than 0.5 secs and are usually caused by the switching off and on of heavy loads.

Equipment that includes motors or heavy loads, such as refrigerators, duplicators, electric fires, kettles etc, are all potential sources of problems. Many of these may operate infrequently and consequently it may be difficult to identify them as the source of the problem. If possible, power them from another circuit.

If a heavy load is switched on the extra power taken from the mains circuit produces a sag whilst the switching off of a heavy load produces a surge. Power supplies have a finite reserve of stored energy which can compensate for short, infrequent disturbances of this type. Larger or more frequent disturbances will prevent the PSU from providing a constant output voltage.

Do not assume that all the sockets in any room are on the same phase; many old buildings may have been subject to many years of modification.

Spikes

Spikes or impulses are short bursts of high energy which last between less than a microsecond up to a few milliseconds. These impulses sit on top of the normal voltage waveform so the total voltage entering the PSU is the sum of the impulse plus the voltage of the sine wave at that time. The PSU has an ability to reject this high frequency signal, but if the total energy of the impulse is sufficient then the PSU will malfunction.

A train of low energy impulses can be as damaging as an isolated impulse of a much greater magnitude. Severe impulses such as those caused by electrical storms or badly suppressed motor switches can damage the PSU and may cause the equipment to reset.

Dropouts and power cuts

Dropouts or brownouts occur when the mains voltage drops to zero for a period, and, like power cuts, may be easier to detect than the other disturbances.

High and low frequency

Normally, the power utilities are required to provide power within 1% of the mean of 50 or 60 Hertz. Although the PSU has the ability to deal with some variation this type of disturbance should be checked for. Some rural and other sites may rely on stand-by generators whose generation frequency may be suspect.

High-frequency noise

High-frequency noise can be caused by arcing contacts or even by high powered radio transmissions. Fluorescent light fittings can cause a voltage which is rarely larger than 10 volts to appear on top of the mains waveform and this type of noise can pass through the PSU, modulate the PSU DC output voltages and even cause jitter on a VDU. Lighting should always be on a separate circuit to the equipment.

Identifying an interference problem

Mains monitoring equipment is generally quite expensive. Some manufacturers will do a site survey for you and provide a report on any problems. However, if this is not an option, you are advised to hire what you need from an electronic test equipment rental firm for the period required. The minimum recommended hire period for a site is a week, as defective equipment often malfunctions completely at random.

Your electrical contractor will be able to advise on this.

Reducing mains interference

If you discover that the problem is due to a shared mains circuit, then the best solution is to arrange for an isolated supply installed by a qualified electrician.

If this is not possible, you should consider re-routing the mains wiring because

- if the earth is a long way back to the distribution box then the earth itself will be floating several volts above ground potential causing electrical noise
- if the mains wiring runs from the distribution box via cable trunking, the close proximity of other noisy cables (especially high current circuits for heavy electrical machinery) may induce additional noise into your circuit.

When a computer is connected directly to another mains-powered unit, the immunity of the stand-alone computer to impulse disturbances is reduced. This is due to the creation of earthing loops via the workstations' many mains leads, and can be improved by laying all the mains leads together to reduce the enclosed loop area. **Do not, however, create a potential safety hazard by tying current-carrying cables into a multi-turn loop; just lay them alongside each other in a straight line.**

Equipment is available for hire or purchase to help isolate or prevent mains interference problems.; some ideas of what is available are given below. Further technical information on mains supply problems is readily available from the manufacturers listed in *Appendix I: Useful addresses*.

Prevention is better than cure, and is often cheaper. If you have a problem, isolate it, and if at all possible, eliminate it.

Mains interference filters

The simplest types of mains interference filters are usually plug-in, and can eliminate a large range of impulses. They cannot however prevent any of the other problems. The more expensive types are permanently wired into the live, neutral and even the earth wires, but this should be done only by a professional electrician. The effectiveness of these filters is largely determined by the quality of the installation work but they are available as high current units which can protect an entire room.

Constant voltage transformers

Constant voltage transformers usually use a magnetically saturated, ferro-resonant, mains transformer which eliminates much mains waveform distortion and can be effective against sags, surges and impulses.

Isolation transformers

Isolation transformers have ultra low coupling between primary and secondary and give very high attenuation of electrical noise.

Uninterruptible power supplies

There are two types of uninterruptible power supply (UPS), on-line and off-line, in which the internally generated mains waveform of both types can either be a square wave of mains frequency, or preferably a sine wave.

The cheaper off-line UPS will power the equipment from the mains supply directly whenever the mains supply is operating within its voltage limits. If however this voltage fails the off-line unit will switch to a battery backup system which generates a pseudo mains supply. If the normal mains voltage recovers the UPS will switch it again through to the load and also use it to recharge the batteries. Backup is limited by the size of the batteries and this is usually sufficient for only 10-30 minutes.

The more sophisticated on-line UPS only supplies power to the load via the internally generated mains voltage. The incoming mains supply indirectly powers this generation under normal conditions with the battery being used under fault conditions. An on-line UPS is the ultimate protection against mains problems ensuring that the site equipment is being permanently powered by a perfect, locally generated mains supply. A single unit could be used to supply an entire room. Current on-line UPS ratings range from 100VA to several kilowatts.

You should note that UPS are electronic devices, and are therefore subject to electrical interference. Make sure that any unit you consider purchasing incorporates in-built protection; if it doesn't, you will have to provide it.

10

Installation

This chapter explains how to install an Econet network. You are advised to seek professional assistance from your local network support agency when installing an Econet network.

Tools required

Before you start fitting the cable to the socket boxes you **must** have the correct tools. Failure to use the correct tools will result in an unreliable installation.

The specialist tools required are listed here. You will also need other tools, such as screwdrivers. A suggested complete tool kit for network installation is given in *Appendix E: Tools required*.

Cable insertion tool

All Econet starter kits are supplied with a plastic cable insertion tool. This is only adequate for a small number of connections and you are advised to purchase a professional IDC insertion tool if you intend to install more than one socket box. These can be obtained from a number of sources including RS Components (Part No. 470-128).

Care should be taken with the professional IDC insertion tools as they can also be used to cut the cable once it has been inserted. You are advised either to remove the cable cutter from the cable insertion tool by carefully removing the screws from the body and then removing the cutter, or to wrap a cable tie around the head of the tool to keep the plastic guard in place.

Cable stripping tool

A special tool is available for removing middle sections of insulation from a length of cable, without cutting the internal wires. A cable stripping tool is available from RS Components, (Part No. 547-442). You are advised to experiment with the depth setting for the cutter before attempting to strip the main cable.

Removing the earth shielding

Remove the earth shielding using a small pair of pointed scissors. Take care not to cut the drain wire which runs within the earth shielding.

Wiring Acorn socket boxes

- 1 Carefully strip about 60mm of the outer insulator and shielding from the cable. Take care; if you nick the earth drain wire it will break when it is inserted into the IDC, and you will have to repair it before continuing. Do not strip off the individual wire insulation.

Do not cut the cable to wire a socket box in the middle of the network.

- 2 Remove the lid from the socket box. Inside, you will see two 3-way white IDCs marked with the letters E (ground or earth), D +, D -, C - and C +.
- 3 Fasten the cable to the board using the cable grips at the side of the printed circuit board.
- 4 Lay the colour-coded wires and the copper ground wire over the appropriate IDC sockets using the following colour coding:

Earth	copper
Data +	white with an orange trace
Data -	orange
Clock -	blue
Clock +	white with a blue trace

If the cable you are using does not comply with this colour coding, you must make sure that one twisted pair is used solely for C + and C - and the other for D + and D -.

- 5 Put a kink in each wire to prevent them from breaking when you insert them into the IDCs:

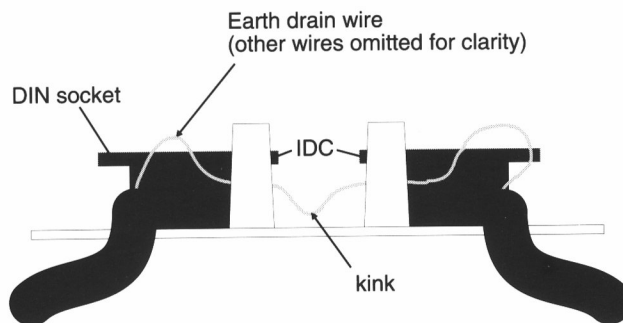

Figure 10.1: Correct technique for insertion of the earth drain wire

- 6 Make sure that the earth drain wire cannot come into contact with either the Econet socket box circuit board or the base of the DIN sockets. (This can cause a short on the network, resulting in damage to the Econet interfaces in the terminals.)
- 7 Push the wire into place using the cable insertion tool. Make that you use the insertion tool the right way round, otherwise the connector will break.

You can work out which way round to use the tool by experimenting with a spare box, using no wire. Gently push the tool into one of the connectors; if it's the wrong way round, you'll feel resistance after the tool has gone in about 3mm. Turn the tool up the other way and try again; it should now go right down to the bottom of the connector with only slight resistance. Mark the tool to remind you which way round to use it.

- 8 If you are fitting a terminator you should cut off any excess cable protruding from the connectors.
- 9 Reassemble the socket box.

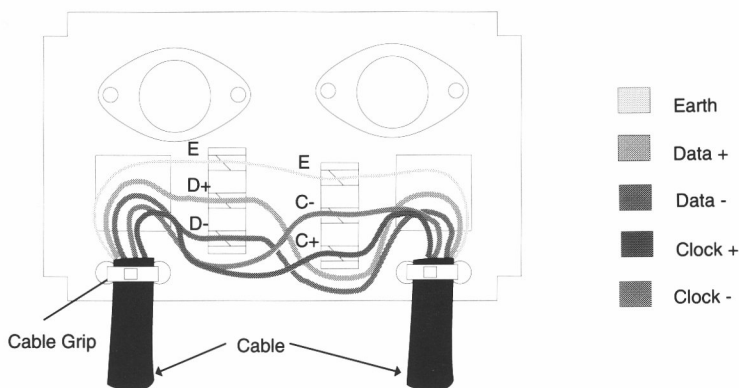

Figure 10.2: Acorn Econet socket box showing cable layout

Wiring SJ Research socket boxes

- 1 Carefully strip about 60mm of the outer insulator and shielding from the cable. Take care; if you nick the earth drain wire it will break when it is inserted into the IDC, and you will have to repair it before continuing. Do not strip off the individual wire insulation.

Do not cut the cable to wire a socket box in the middle of the network.
- 2 Remove the lid from the socket box.

- 3 Lay the colour-coded wires and the copper ground wire over the appropriate IDC sockets using the following colour coding:

Earth	copper
Data +	green
Data -	red
Clock -	yellow
Clock +	blue

If the cable you are using does not comply with this colour coding, you must make sure that one twisted pair is used solely for C + and C - and the other for D + and D -.

- 4 Put a kink in each wire to prevent them from breaking when you insert them into the IDCs:

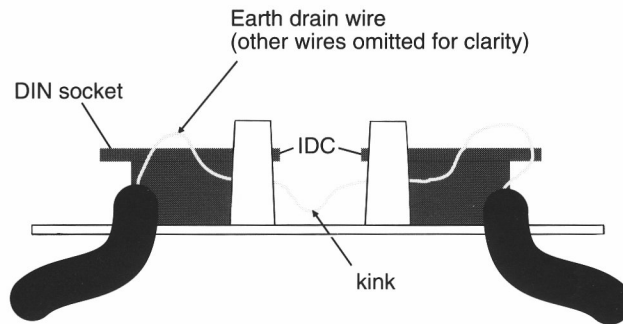

Figure 10.3: Correct technique for insertion of the earth drain wire

- 5 Make sure that the earth drain wire cannot come into contact with either the Econet socket box circuit board or the base of the DIN sockets. (This can cause a short on the network, resulting in damage to the Econet interfaces in the terminals.)
- 6 Push the wire into place using the cable insertion tool. (Make that you use the insertion tool the right way round, otherwise the connector will break.) You may use any of the IDCs contained in the SJ Research socket box. You can use the spare connectors if the cable breaks when you insert it.

You can work out which way round to use the tool by experimenting with a spare box, using no wire. Gently push the tool into one of the connectors; if it's the wrong way round, you'll feel resistance after the tool has gone in about

3mm. Turn the tool up the other way and try again; it should now go right down to the bottom of the connector with only slight resistance. Mark the tool to remind you which way round to use it.

- 7 If you are fitting a **terminator** you should cut off any excess cable protruding from the connectors.
- 8 Reassemble the socket box.

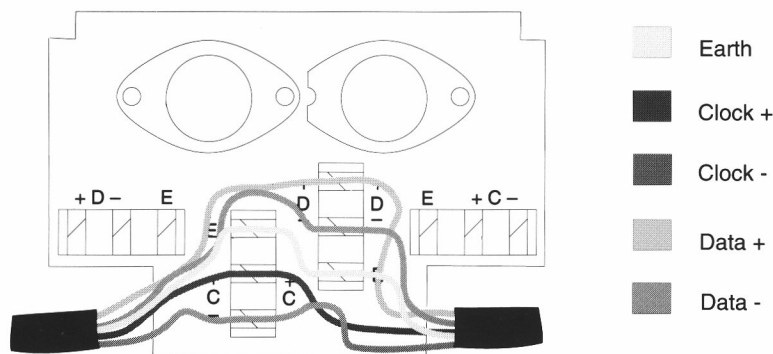

Figure 10.4: SJ Research Econet socket box showing cable layout

Joining cable lengths

If you have to join two lengths of cable, you can either use a BT Block Terminal type 77A or you can choose to use a soldering method.

Joining two lengths of cable using a BT Block Terminal type 77A

The easiest way to join two lengths of cable is to use a BT Block Terminal type 77A. This consists of two pairs of IDCs which provide a straight through connection for the ends of the two cables. SJ socket boxes have this feature built into the design.

- 1 Strip about 60mm of the outer insulator and shielding from the cable. Take care; if you nick the earth drain wire it will break when it is inserted into the IDC.
- 2 Remove the lid from the box. Inside, there are four 3-way white IDCs marked with the numbers 1 to 6 for each pair of IDCs.
- 3 Fasten the cable to the board using the cable grips at each end of the printed circuit board.
- 4 Lay the colour coded wires and the copper ground wire over the appropriate IDC sockets. Ensure that the colours are matched and that no wires are crossed. Do not strip off the individual wire insulation. Push the wire into place using the cable insertion tool as described under *Wiring Acorn socket boxes*.

- 5 Put a kink prior in the wire to prevent it breaking when it is inserted into the IDCs.
- 6 Cut off any excess cable protruding from the connectors.
- 7 Reassemble the socket box.
- 8 To prevent strain on the soldered connections, fix the socket box down.

Wiring a BT 77A joint box for use with Econet illustrates a BT 77A joint box before, during and after wiring.

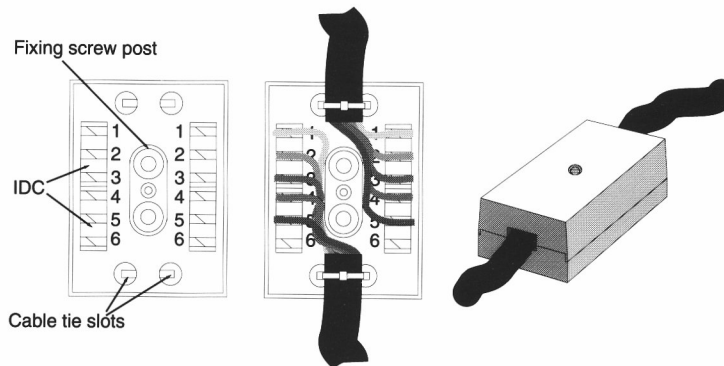
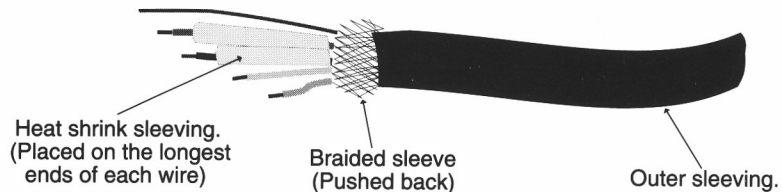

Figure 10.5: Wiring a BT 77A joint box for use with Econet

Soldering two lengths of cable

The internal wires can be carefully stripped back and soldered.

- 1 Remove about 50mm of the outer covering from the cable and slide the braiding back.
- 2 Remove any foil wrapping which may be around the cable.
- 3 Cut the ends of the cable and remove about 10mm of sleeving from each individual conductor. It is important when cutting the cable to stagger the length of the wires to ensure an overall more reliable connection:



- 4 Place heat shrink sleeving over the main body of the cable and over each of the individual conductors to be joined:

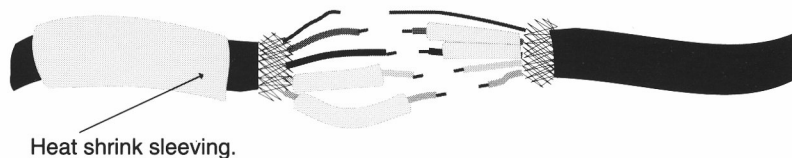

Note that the Earth wire is not normally sleeved, but it is advisable to sleeve it when making a soldered joint to provide mechanical strength.

- 5 Solder the corresponding wires together making sure that the two ends of the wires overlap for a few centimetres of their length:

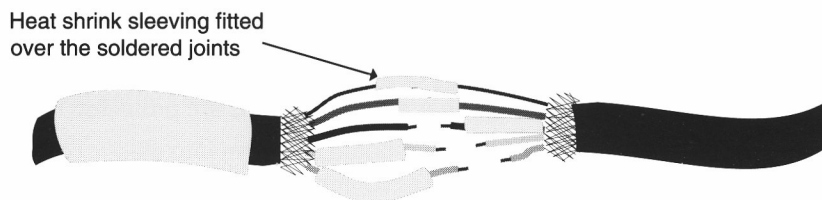

- 6 Slide the sleeving over all the soldered joints and warm with the soldering iron or a suitable hot air source until there is a tight fit over the joints.
- 7 Slide the braiding over the conductors making sure that the two ends overlap and then carefully slide the sleeving over the braiding and warm as before.

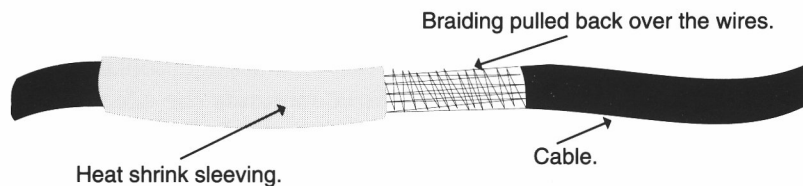

- 8 Secure the joint to make sure that it will not be subjected to any stress (soldered joints have poor mechanical strength).

SJ Research transient suppressors

Transient suppressors are fitted using the tools required for a normal Econet socket box, and the installation method is very similar with the following additions.

- When the cable has to leave a building and be run outside it is often more convenient to cut the cable in order to facilitate its installation. If the cable is cut the transient suppressor makes a convenient junction between a cable coming into a room from outside, and the internal wiring. Two sets of identical IDCs are provided.
- A solid earth connection is required for reliable operation. This is best made with cable of 1.0 square mm cross-section or more, from the earth screw terminal in the box to a copper earthing stake hammered into the ground. A mains earth is not recommended. Connection to a water pipe or other service entering the ground is allowed, provided the connection is made near the point of entry of the service to the building, and that precautions are taken to make sure that the connections are protected from corrosion.
- Outdoor cables should be drawn into plastic conduit, and buried in the ground at a minimum of 600mm depth. If this is not possible, cables may be slung between buildings, using galvanised steel wire to support the weight, and heavy duty screw eyes to secure them at each end. The data cable must not be subjected to mechanical stress, so you must make allowances for wind and ice.

Note that a transient suppressor will **not** protect against a direct lightning strike. However, when lightning strikes occur in the locality, substantial voltages can be induced in cables, and the transient suppressor will generally protect against these, normally protecting the semiconductor devices in the computers connected to the network.

SJ Research and Acorn Computers can accept no responsibility for any damage however caused to any device connected in any way whatsoever to a SJ Research transient suppressor.

If you are using other devices, consult the installation instructions, and seek advice from the manufacturer.

Connecting the clock and terminators

When you set up an Econet network for the first time, you need to activate and test the network. The tests you need to perform are described in this chapter.

- 1 Test the wiring as described under *Measuring resistance from the clock to the terminators* on page 80.
- 2 If you are using removable terminators place these at each end of the network and test them as described under *Resistance and DC testing* on page 76.
- 3 Make sure that the clock speed is correctly set by the links in the clock box as described in the chapter section entitled *The Econet clock*.
- 4 Check the voltages present on the Clock + and Clock - lines as specified under *Identifying faulty Econet interfaces* on page 82. If you do not obtain a reading within the ranges given, the clock is faulty and should be replaced.
- 5 Connect the clock box in the middle of the network.
- 6 Connect the power supply to the clock box and switch on.
- 7 Check the voltages present on the Clock and Data lines as specified under *Identifying faulty Econet interfaces* on page 82. If you do not obtain a reading within the ranges given, there is a problem with terminators, clock or the wiring. Repeat the tests outlined in the chapter *Testing the network* on page 75.
- 8 Using an Oscilloscope examine the Clock + and Clock - waveforms as described under *AC testing* on page 86. If you do not obtain the expected waveforms, the clock or terminators may be faulty.

When the network has passed all of these tests it is ready to accept Econet terminals and file servers, and bridges if required.

Equipment

You will need the following equipment to test your Econet installation.

- a good quality multimeter capable of accurately reading < 0.5 ohms, and fitted with fine probes
- a shorting plug; you will need to make this yourself.

The following equipment is useful for speeding up the testing:

- a dual trace oscilloscope
- a test box; either an EMA box or a FLAT box.

The EMA (Econet Maintenance Aid) test box is no longer available, although some of the functionality can be obtained using the circuits described in the December 1987 and January 1988 issues of BBC Acorn User. The FLAT (First Line of ATtack) box offers similar facilities to the EMA box; details can be obtained from Alsystems.

Note that:

- The testing outlined in this section assumes that an external Acorn or SJ clock and appropriate terminators have been used for the installation.
- Networks using the FileStore internal clock and termination may generate unpredictable results.
- Networks using Interlock termination will generate unpredictable results if there is line driver failure on either of the machines containing the terminators.

Resistance and DC testing

DC testing is used to test for:

- breaks in the cable
- faulty passive terminators
- short circuits between any of the cables.
- high resistance in the cable.

DC testing can also be used to help you map out the layout of your network.

Making a shorting plug

To make one of these you need a 5-pin 180 DIN plug, some wire, a soldering iron and solder. You can obtain a DIN plug from any electronics stockist, or you could use the end from a damaged Econet lead. An exploded view of a shorting plug is shown below:

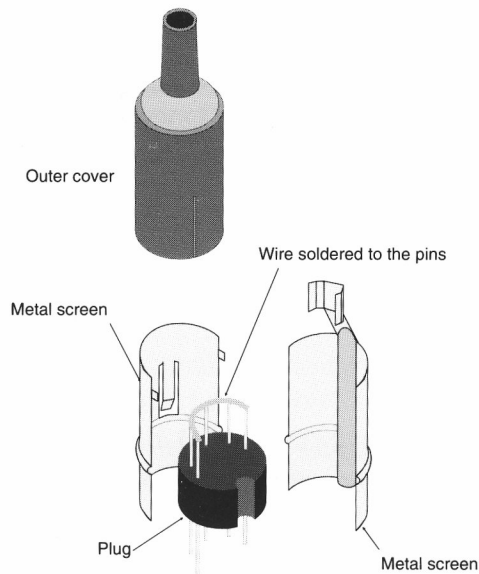

Figure 11.1: Exploded view of a shorting plug.

Test the plug by measuring the resistance across all possible pin out configurations. The resistance should be the same with all pin out configurations. If they are not, there is a faulty soldered joint on the plug.

Testing for cable breaks

The first test which should be performed is a continuity test. This checks for any breaks in the cable.

- 1 Disconnect all the stations, peripherals, clocks, file servers and bridges from the network. **If you fail to do this, damage may be caused to any equipment which is left connected to the network.**

Note that if your network relies on the FileStore internal clock and termination or Interlock termination, the terminator only functions correctly when the machine containing the terminated interface is connected to the network and switched **on**.

During these tests, the FileStore and Interlock should be treated in the same way as SJ Research terminators.

- 2 If fitted, SJ terminators should be removed.
- 3 Take the shorting plug and push it into the socket in a terminator at one end of the network.
- 4 Begin testing at the break where the clock is inserted in the network (point A in *Figure 11.2: Test points on a section of Econet network*). On networks which do not have a clock in the middle of the cable, remove one of the terminators and work from one end to the other.

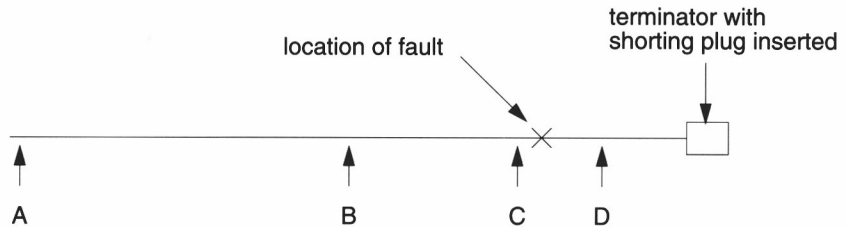
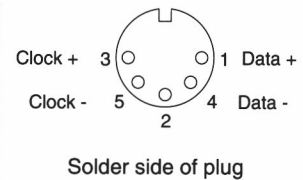

Figure 11.2: Test points on a section of Econet network

- 5 Measure the resistance of the cable in the following order:

	Earth to Line Tests	Typical Value
1	Earth (Pin 2) to Clock + (Pin 3)	<20 ohms
2	Earth (Pin 2) to Clock - (Pin 5)	<20 ohms
3	Earth (Pin 2) to Data + (Pin 1)	<20 ohms
4	Earth (Pin 2) to Data - (Pin 4)	<20 ohms



- 6 Now check for short circuits between lines by repeating the tests in this order:

	Line to Line Tests	Typical Value
1	Clock + (Pin 3) to Earth (Pin 2)	<20 ohms
2	Clock + (Pin 3) to Clock - (Pin 5)	<27 ohms
3	Clock + (Pin 3) to Data + (Pin 1)	<27 ohms
4	Clock + (Pin 3) to Data - (Pin 4)	<27 ohms

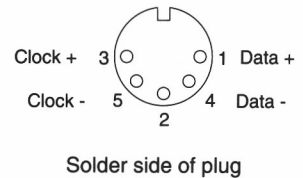

You should obtain maximum readings of 27 ohms or less on a 250m arm of a 500m network when the test plug is placed in the terminator. Installations using SJ Research cable will have readings which are 2-3 ohms higher in value than those of the first test, due to the characteristics of the SJ Research cable.

You will find that the readings obtained in the first test, and the first reading in the second test are significantly lower than the remaining readings in the second test. This is due to the increased conductor size which the Earth shield and drain wire provide.

Deviations from the given values can indicate a number of possible problems, including:

- the network is too long
- the clock is not in the centre of the network
- the wrong cable type may have been used
- there may be high resistance joints in the cable.

It is possible for the network to be continuous and yet exhibit characteristics which indicate that it is too long, or that the wrong type of cable has been used.

It is important to realise that whilst a network with this type of 'fingerprint' may function it will not do so unless you reduce the clock speed.

If only some of the readings are affected then you may also have one or more short circuits or open circuits on the cable.

Isolating the problem

To isolate the problem, move to the half-way point of the cable (point B in *Figure 11.2: Test points on a section of Econet network*), and repeat the tests. The resistance on shorter lengths of cable is less, so the values of your readings will be reduced.

If the problem remains, halve the distance again, (point C), and repeat the test. Continue to do this until the readings follow the normal pattern. This enables you to identify which part of the cable contains the fault. You can then work between the known good point and the bad point, points C and D in the example, until you isolate the fault.

When you have found one fault, don't assume you have found them all; rectify the fault and then repeat the tests again until you have isolated every fault.

Measuring resistance from the clock to the terminators

Remove the shorting plug.

If your network uses SJ terminators, you will have removed them for the first test; replace them now.

Measure the resistance from the clock position through the terminators. You should obtain readings like those shown below:

Line to Line Tests	Typical value
Clock + (Pin 3) to Clock - (Pin 5)	110 to 160 ohms
Data + (Pin 1) to Data - (Pin 4)	220 to 260 ohms

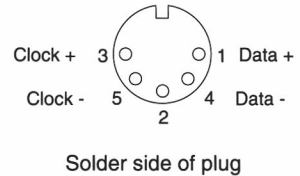

The exact value you obtain will vary from network to network because the final value obtained is made up from the component values in the terminator and the cable resistance.

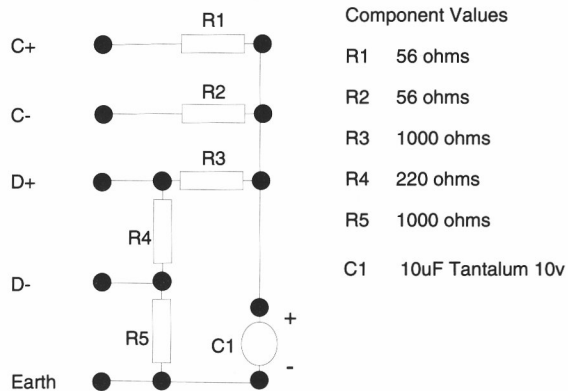

Figure 11.3: Econet terminator circuit diagram

You can see that the values are made up as follows:

Clock + to Clock - = R1 + R2 + cable resistance

Data + to Data - = R4 + cable resistance

This is true for all the resistance readings on the network. If you obtain readings which are not within the specified range then the terminator is faulty and should be replaced or repaired.

If you do replace components in the terminators then you must ensure that capacitor types and resistance tolerances etc are adhered to.

In addition to the above readings, you can also perform the following tests:

Earth to Line Tests	Typical value
Earth to Data +	1220 ohms
Earth to Data -	1000 ohms
Earth to Clock -	2276 ohms
Earth to Clock +	2276 ohms

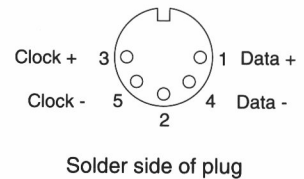

Line to Line Tests	Typical value
Clock + to Data +	1056 ohms
Clock - to Data +	1056 ohms
Clock + to Data -	1276 ohms
Clock - to Data -	1276 ohms

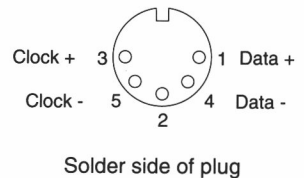

Using the circuit diagram, shown in *Figure 11.3: Econet terminator circuit diagram*, you can use these readings to identify the faulty component(s). Readings which are inconsistent with the figures given above may indicate a faulty capacitor.

Ideally the capacitor should be checked using an oscilloscope as described in the section AC testing. Alternatively, to check the capacitor, carefully desolder it and repeat the tests. (Note that the capacitor is polarised as shown. Make sure you re-insert it correctly.)

Creating a map of the network

Often it is not possible to determine the path which the network follows by simply following the cable run. The following technique will enable you electronically to trace the path of the cable.

- 1 Disconnect all the stations, peripherals, clocks, file servers and bridges from the network. **If you fail to do this, damage may be caused to any equipment which is left connected to the network.**
- 2 Take the shorting plug and push it into the socket in a terminator at one end of the network.
- 3 Select a pair of wires, Clock + and Clock -, which you can use to measure the resistance of the cable.

- Using the multimeter, measure the resistance of the selected cables at each socket.

You will find that the closer you get to the shorted-out terminator, the lower the resistance reading. From your readings, it is possible to map the network as shown in Figure 11.4: *Mapping the cable layout of an Econet network*. All measurements are in ohms:

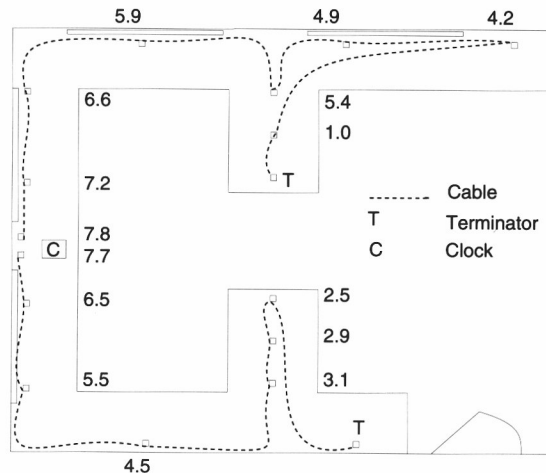

Figure 11.4: *Mapping the cable layout of an Econet network*

Your map should include the building layout, the location of all bridges, clocks, file servers, printers etc and all protection devices; isolation switches, mains circuits etc. You should always keep your network map up to date.

Identifying faulty Econet interfaces

It is not normally practical to take precautions against absolutely all possible sources of interference, and so line drivers will occasionally fail.

So, given that there can be faulty line driver chips affecting the whole network, how do you go about locating the faulty machines? And if the network is working reasonably well, how do you determine if there are any faulty drivers at all?

If you believe that there may be a faulty Econet interface on the network, disconnect all stations from the network, and check the clock, network cable, transient suppressors (if fitted) and terminators as previously described.

If there is no problem with the network, you should test for a faulty Econet interface by carrying out the following tests.

- 1 Disconnect all the stations, peripherals, clocks, file servers and bridges from the network.
- 2 Test the voltages from the clock, without it connected to the network. Using a DC voltmeter, measure the voltages on the Clock +, Clock -, Data + and Data - with respect to Earth. You should expect to find voltages of the following magnitude:

Earth to Clock +	4.0 volts
Earth to Clock -	3.7 volts
Earth to Data +	0.0 volts
Earth to Data -	0.0 volts

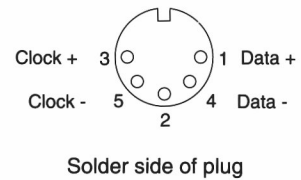

- 3 If this not the case, replace the line driver in the clock. When the clock has passed this test, reconnect the clock and repeat the test. Due to the termination applied to the Data + and Data you will now obtain readings of these magnitudes:

Earth to Clock +	4.0 volts
Earth to Clock -	3.7 volts
Earth to Data +	2.2 volts
Earth to Data -	1.7 volts

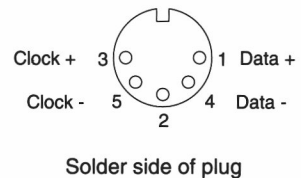

These voltages will vary according to the type of clock box you are using and the length of the network. The figures are approximate; Data + may be anything from 1.8 to 2.3 volts, and Data - should be 0.3 to 0.5 volts less than Data +. If the voltages are too high with no stations connected, you may have a faulty network earth connection between the clock box and terminators.

- 4 Now start to connect the terminals to the network one at a time. As each machine is added, check the data voltages. Then switch the machine on, and check the data voltages again.

As machines are added you will find that the voltage will drop slightly; the voltage drop depends on the number of machines connected.

A dramatic voltage change as you add a machine is an indication of a faulty Econet interface or lead. Change the lead and if the problem persists remove the machine, and change its Econet interface. If the machine is a BBC Model B

then replace the line driver, this is an SN75159N and is numbered IC 93. If the machine still causes a dramatic voltage change take it to your Acorn Dealer or Approved Service Centre for repair.

Faulty line drivers in early BBCs (PCB Issue 3 or earlier) can also cause no clock on other stations.

- 5 When all machines are connected, check that each can communicate with the file server. Machines reporting `Net Error` or `Station Not Present` probably have blown line driver chips.

It is possible for damaged chips to continue to work perfectly, although their internal connections have been partly destroyed. These chips are very sensitive to further mild overloads. It is therefore not unusual after a serious problem has been corrected, for other line drivers to fail later, and for no apparent reason. Unfortunately, there is no practical way to identify such chips.

Identifying faulty bridges

Like line drivers, faulty bridges are often difficult to identify simply because they often continue to work when partly damaged.

The Econet Bridge designed jointly between Acorn Computers and SJ Research is not covered in this section. Please refer to the manual supplied with the SJ Econet Bridge for more details about this product.

Testing an Acorn bridge

A bridge contains two Econet interfaces, so the first test is to identify whether the line driver circuitry is functional by performing the tests in the section *Identifying faulty Econet interfaces* on page 82.

To help you to diagnose more complex faults you will need:

- a terminator box
- a clock box with associated power supply
- four 5-pin DIN leads
- an Econet Y junction or T-piece
- the Unit Under Test (UUT).

Connect the bridge as follows:

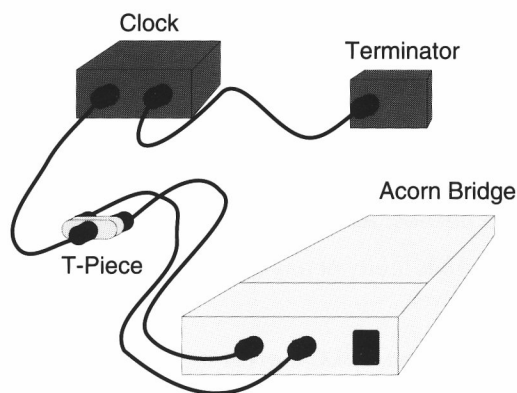

- 1 Connect the terminator to the clock box using a 5-pin DIN lead.
- 2 Connect the Econet Y junction or T-piece at the single socket end to the other socket on the clock box using another 5-pin DIN lead.
- 3 Connect the other two sockets on the Econet Y junction to the two panel mounted sockets on the rear face of the Unit Under Test (UUT) using the remaining 5-pin DIN leads.
- 4 Connect the power supply unit to the clock box and switch on.
- 5 Connect the UUT to the mains supply and switch on.
- 6 Start the self-test by pressing the switch in the recess under the front section of the UUT.
The LED in the recess should flash with an even mark-space ratio.
- 7 Check that the LED continues to flash for at least 30 seconds, and then switch the unit off and on again. The LED should now remain on.

If the LED does not flash or flashes with a period of between 1 and 8 short flashes followed by a number of flashes, the unit is faulty. Take note of the number of flashes and take the unit to your Acorn Dealer or Approved Service Centre for repair.

The meanings of the different numbers of flashes are:

0 flashes: Microprocessor is not operational

The microprocessor is not capable of starting due to possible faults in the microprocessor/microprocessor clock / IC18 / EPROM / Address lines / Data lines / Test switch / LED or power supply.

1 flash: RAM error

ICs 5, 6, 7 or 8 are faulty or an address or data line is faulty or address decoding is not functioning properly.

2 flashes: ROM checksum error

The ROM is faulty or any of the 1 flash errors may exist.

3 flashes: ADLC 1 error

IC 18 is faulty or any of the IC 18 input circuitry may be faulty e.g. clock detect, data receiver.

4 flashes: ADLC 2 error

IC 12 is faulty or any of the IC 12 input circuitry may be faulty e.g. clock detect, data receiver.

5 flashes: Loopback from 1 to 2 error

IC 18 and transmit circuitry failure or IC 12 and receive circuitry failure.

6 flashes: Loopback from 1 to 2 error

IC 12 and transmit circuitry failure or IC 18 and receive circuitry failure.

7 flashes: Net 1 number error

Links 12-19 should be set to 1 or IC 17 or RP2 is faulty, or there is an address or data fault into the area of IC 17.

8 flashes: Net 2 number error

Links 4-11 should be set to 2 or IC 15 or RP1 is faulty, or there is an address error or data fault into the area of IC 15.

AC testing

You need an oscilloscope and / or an EMA test box or a FLAT box to perform these tests.

The examples are typical readings when the oscilloscope is set to DC coupling. It is very important to test the network with DC coupling because it will show up deficiencies in the Earth continuity.

These examples are rather general, and you may find that the output from the network under test exhibits elements of these. You should be aiming to achieve the example shown in *Figure 11.5: Normal clock waveform* for a normal clock waveform.

- 1 Disconnect all the stations, peripherals, file servers and bridges from the network.
- 2 Using an oscilloscope check the Clock + and Clock - lines; there should be no voltage difference between them. The following waveforms may be obtained.

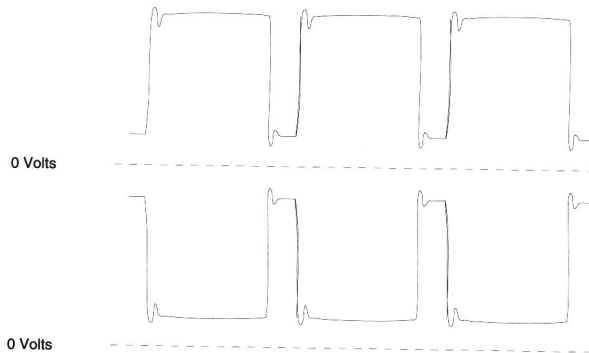

Figure 11.5: Normal clock waveform

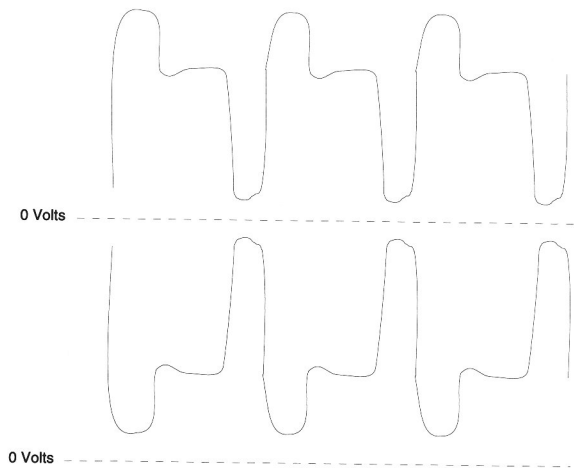

Figure 11.6: Unterminated clock waveform

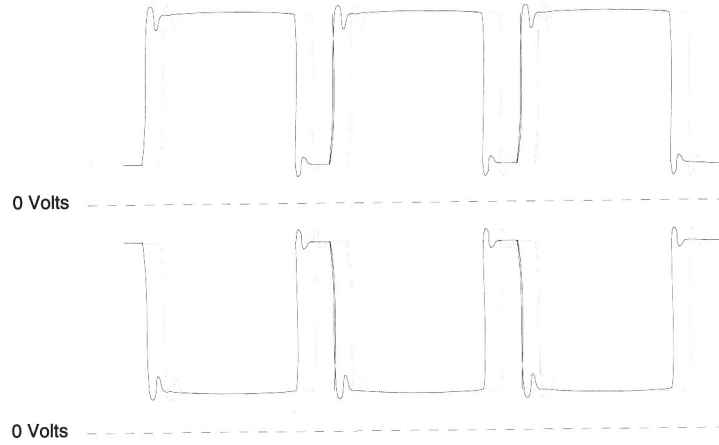

Figure 11.7: External and FileStore clock clash

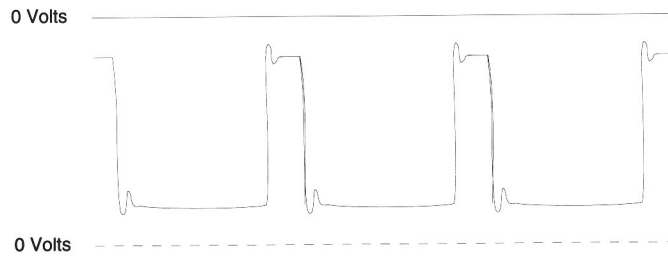

Figure 11.8: Clock + shorted to ground

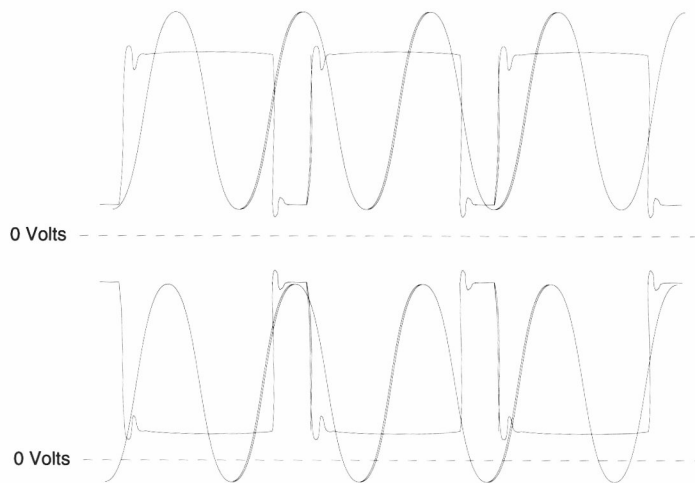

Figure 11.9: External interference on the clock signals

Earth discontinuity can be identified by the clock waveform appearing over or fluctuating around the DC 0 volt reference. The waveform which is shown in *Figure 11.10: Earth continuity problems as displayed on the clock signals* indicates a break in the Earth continuity of an Acorn clock, via a fault with link R7.

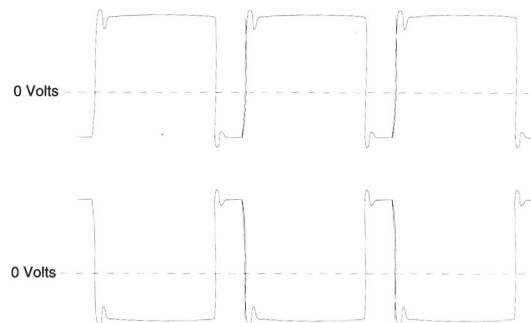

Figure 11.10: Earth continuity problems as displayed on the clock signals

The quality of the clock signals is affected by the number of machines connected to the network. A good indication of the quality of the clock signals can be obtained by looking at the clock on pin 4 (TXC) or 5 (RXC) of the MC68B54 integrated circuit, which is part of the Econet interface. This shows the clock signals after they have been cleaned up by the Econet interface.

You may identify a faulty clock and/or terminator(s) while you are testing. You should be able to identify the faulty component by removing the clock from the network and scoping Clock + and Clock - directly.

If the clock is faulty it should be replaced or repaired.

If the terminator appears to be faulty, but has passed all the resistance tests, then the capacitor in the terminator has failed and should be replaced.

The data signals need only to be checked with a DC voltmeter as described above.

Note: The data voltage values will vary considerably if the measurement is taken on an active network due to the polling interruptions

When the network has passed the tests described under *Testing the network* on page 75, it is ready to accept Econet terminals and file servers, and bridges if required.

BBC Model B, Master 128, Master Compact and Archimedes computers can be used in any combination on an Econet network.

Adding a new station to the network

Adding a new station to the network involves the following steps:

- fitting an Econet interface to the new network station
- setting the station number
- connecting to Econet network
- configuring the station for network use.

The procedure for each type of machine is described in the following subsections:

- *Setting up a BBC Model B station* on page 92
- *Setting up a Master 128 or Compact station* on page 95
- *Setting up an Archimedes station* on page 97.

Setting the Econet station number

The station number of each machine on the network must be unique. Ideally, the file server should have a larger station number than the terminals it supports. Normally the file server is numbered 254.

It is recommended that the client terminals start from a minimum of 2 upwards. There are two reasons for this:

- With the exception of BBC Model Bs, a new network terminal always defaults to the number 1. If there is already a station 1 on the network, no network communication can take place from this station or the new station.
- If a machine detects that the network is busy it will wait for a period of time before attempting to use the network again. If the machine is a Model B or a Master, the period of time it waits is determined by the station number; the bigger the number the less time there is between retries, hence the

recommendation that file servers have large station numbers. This feature is not implemented in RISC OS, but it is still good practice on RISC OS machines.

It is also recommended that client machines are numbered in increments of 10.

For instance, on the 1st network which is installed the numbering may be 10, 20, 30, 40 etc. Additional networks may then have stations numbered 11, 21, 31, 41 etc and 12, 22, 32, 42 etc. This helps to ensure that wherever a machine is placed there will never be a station number clash.

Setting up a BBC Model B station

Fitting the Econet interface

The Econet interface for a Model B BBC microcomputer is fitted as a number of separate electronic components, inside the computer, and should only be fitted by a qualified dealer or service centre.

Setting the identity of a BBC micro

In BBC Model B computers fitted with an Econet interface there is a row of 8 links in the top left hand corner of the board, marked S11.

To gain access to these links, the lid of the computer must be removed. Please refer to the *User Guide* for further details and safety precautions.

The links form an 8-bit binary number representing the computer's station identity.

On the BBC Model B, the least significant bit is the link nearest to the rear of the case; the most significant bit is the link nearest to the front of the case:

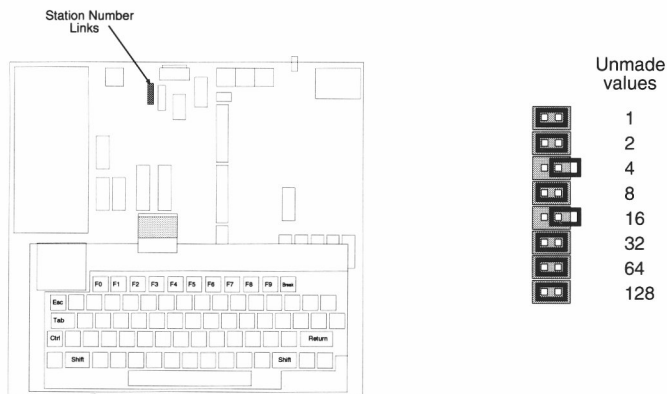

Figure 12.1: Setting the Econet station ID to 20 on a BBC Model B

On the BBC Model B+, the links are laid out in the opposite sense; the most significant bit is the link nearest the rear of the case.

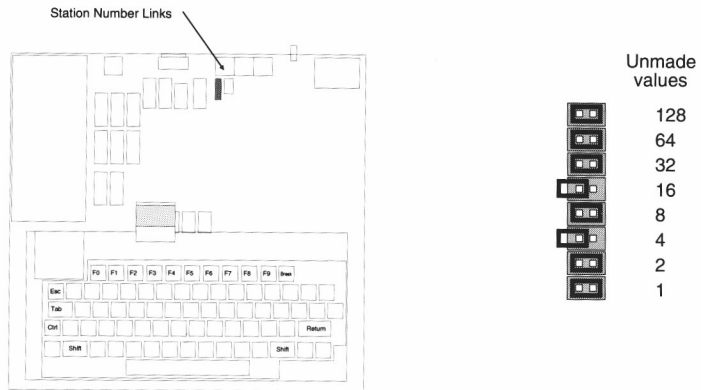

Figure 12.2: Setting the Econet station ID to 20 on a BBC Model B+

If a link is made, the bit is zero; an unmade link implies a 1 bit. As an example, to obtain the number 20 ($4+16$), links 3 and 5 should be unmade and the rest made (counting the rearmost link as number 0). Unused links may be parked by inserting them on only one of the two pins.

Connecting the station to Econet

Connect the station to Econet by plugging the 5-pin DIN connector into the Econet socket on the machine and into a socket box or terminator box on the network. Switch the station on and log on. If no error messages are displayed, the station has been set up correctly.

If two stations are set up to the same number, you must disconnect one of them from Econet or turn it off, and change its station number to an unused one before reconnecting or turning it on again.

Configuring the station

You can configure all stations on the network to start up the same way, when *Shift-Break* is pressed. You set this up using the autostart facility, which works similarly to the autostart at log on, described in the *BBC User Guide*.

For example, you could arrange for every station to start up and display a menu of programs for users to choose from. The programs would be downloaded from the network file server, without the need for users to log on individually.

Whenever a user resets the computer by pressing *Shift-Break*, the station automatically tries to log on as the user *BOOT*. The user *BOOT* can have a directory and *!BOOT* file, just like any other user. This can be set up to contain the starting routine you want the stations to follow.

The following process describes how to configure the machines to autostart. If you need information on how to create boot sequences for the various machine types you should refer to the appropriate *File Server Managers Guide* or the *User Guide* supplied with the machine.

Changing station configuration

You can change the configuration of individual stations by making links on the keyboard. To do this, you first have to remove the lid of the computer; please refer to the *User Guide* for further details and safety precautions.

Follow this procedure to gain access to the keyboard links:

- 1 Remove the two screws in the back panel.
- 2 Remove the two screws on the underside of the computer, near the front, and carefully remove the lid.
- 3 Disconnect and carefully ease off the keyboard.

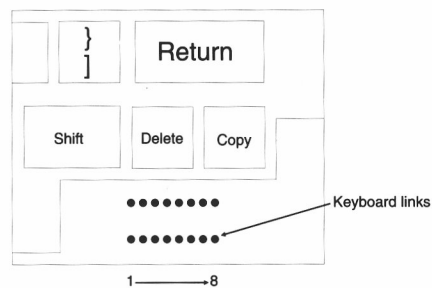

Figure 12.3: The keyboard links on the BBC Model B and B+.

Here is a summary of what the links do:

- Link 1, when made, causes the default filing system at reset to change from DFS to NFS (assuming that the machine contains a DNFS ROM).
- Link 2 is reserved.
- Links 3 and 4 select the disc drive set rate (assuming that the machine contains a DNFS, or DFS, or ADFS ROM and Floppy Disc Interface).
- Link 5, when made, link causes *Break* to act as *Shift-Break* and *Shift-Break* to act as *Break*.

- Links 6, 7 and 8 select the screen mode at power up and after a reset.

You may need to wire up Link 1 and Link 5. You can do this either by soldering a wire link across the appropriate pair of holes, or by soldering a standard 8 way SPST switch in a 16 pin DIL package to the keyboard.

Setting up a Master 128 or Compact station

Fitting an Econet interface

The Econet interface for the Master 128 and Master Compact is supplied as a module that should be fitted inside the computer case. A ROM (Read Only Memory) containing the Econet interface programs is also supplied, which should also be fitted internally. Fitting instructions are supplied with the interface, but if you are not sure how to do this, your supplier will fit these components for you.

Connecting to Econet

Connect the station to Econet, using a lead with a 5 pin DIN connector plugged into a network socket box or terminator box and switch on.

Setting the station number

When you first turn the station on, its display will probably include the words:

```
Badly configured station number
```

This is to remind you to set a suitable station number.

On the Master 128 and Master Compact computers, the station number is held in non-volatile memory and is set up using a utility program stored on the FileStore or file server.

Utility programs are supplied with FileStore E01 and E01S units, and their use is described in the *FileStore Network Managers Guide*, also supplied with FileStore. Users of older file servers should in the first instance either download the utilities from Acorn Support BBS (see *Appendix D: Software available on the Acorn Support BBS*) or contact the supplying dealer.

To set the station number:

Log on as SYST at the station

Type:

```
*LIB $.Library1
```

Then press Return.

This selects the correct library. Now type:

*SET *ddd*

where *ddd* is the station number you wish to set.

Then press Return.

Reset the station and try to log on.

If you have set the station number to the same one as another station or FileStore unit which is connected and turned on, you will get a error message. Disconnect the other station from Econet or turn it off, change its station number to an unused one and reset it. Then reconnect or turn on the other station and try to log on again.

The SET command is stored in the directory \$.Library1 on each of the discs supplied with the FileStore. This command is designed to be used only by the Network Manager. You should therefore be careful to ensure that other users are not allowed access to this program, for example by setting the access to LR.

Setting other station parameters

Most characteristics of network stations are set by users to suit their own preferences, using the Control Panel program or *CONFIGURE command.

You may need to:

- set the file server number
- set the printer server number
- set the default filing system ROM number
- configure the network printer
- configure autoboot with *Break*
- configure autoboot with *Shift-Break*.

To set the file server number, type:

```
*CONFIGURE FS [ddd] .ddd
```

where *ddd* is the station number and [*ddd*] is the network segment number, up to 254.

To set the printer server number, type:

```
*CONFIGURE PS [ddd] .ddd
```

where *ddd* is the station number and [*ddd*] is the network segment number, up to 254.

To set the default filing system ROM number, type:

```
CONFIGURE FILE n
```

where *n* is the default filing system type, as follows:

8 = ANFS

9 = DFS

13 = ADFS

Use the command *ROMS to determine in which position your filing systems are located.

To configure the network printer, type:

```
*CONFIGURE PRINT 4
```

To configure autoboot with *Break*, type:

```
*CONFIGURE BOOT
```

To configure autoboot with *Shift-Break*, type:

```
*CONFIGURE NOBOOT
```

Certain other characteristics should only be set by the Network Manager. These control how the station's memory is used in network operations (to minimise problems when using programs designed for the Model B BBC computer memory map) and which library the station will use.

To set these options:

Log on as SYST on the station

Type:

```
CHAIN $.Utils.SETSTATION
```

Press Return and follow the instructions given on the screen. As a minimum, you should normally select the `Findlib` option, to make sure that the station selects the correct library when a user logs on.

Setting up an Archimedes station

Fitting an Econet interface

The Econet interface for the Archimedes computer is supplied as a module which should be fitted inside the computer case. The ROM (Read Only Memory) which is also supplied, should be discarded, as the programs required are built into the Archimedes. Fitting instructions are supplied with the interface, but if you are not sure how to do it, your supplier will fit it for you.

Connecting to Econet

Connect the station to Econet, using a lead with a 5-pin DIN connector plugged into a network socket box or terminator box and switch on.

Setting the station number

When you first turn the station on, its display will probably include the words:

```
Badly configured station number
```

This is to remind you to set a suitable station number.

On the Archimedes computer, the station number is held in non-volatile memory and set up using the utility program `SetStation` which is on the file server. Early versions of this utility were called from the `*` prompt by typing `SETSTATION station_number`. The latest version can be accessed by simply double-clicking on it. It is important that you use the latest version of this utility as earlier versions will not function correctly with RISC OS 3.

To set the station number:

Log on as SYST at the station

Display the contents of the directory `$.ArthurLib`.

Double click on the SETSTATION utility. A window opens with the prompt:

```
New station number :
```

Enter the station number you wish to set in the range 2 to 254.

Reset the station and attempt to log on

To confirm the station number you have given, you can type:

```
*HELP STATION
```

If you have set the station number to the same as another station or FileStore which is connected or turned on, you will get an error message. Disconnect the other station from the network or turn it off, change its station number to an unused number and reset it, then reconnect or turn on the other station.

The SETSTATION command is stored in the library `$.ArthurLib`. It is designed to be used only by the Network Manager. You should therefore be careful to ensure that other users are not allowed access to this program, for example by setting the access to LR.

Setting other station parameters

Most characteristics of network stations are set by users to suit their own preferences, by using the `*CONFIGURE` command.

You may need to set the:

- file server number
- printer server number
- library option
- default printer output

To set the file server number, you may use a number as before, or you may specify a disc name. To do this, type:

```
*CONFIGURE FS Station_number | Disc_name
```

Station_number is specified in the form *[ddd].ddd* where *ddd* is the station number and *[ddd]* is the network segment number, up to 254.

disc_title is the name of the file server disc you wish to log on to, and must be the name of a disc which is connected to the file server you wish to log on to.

To set the printer server number or Econet printer server name, type:

```
*CONFIGURE PS Station_number | Printer_server_name
```

where the station number is as defined above. The Econet printer server name is set by the printer server software. Not all Econet printer server software allows identification by name.

To set the library option, type:

```
*CONFIGURE LIB 0|1
```

where 0 selects \$.Library and 1 selects \$.Arthurlib automatically.

To set the default printer output, type:

```
*CONFIGURE PRINT n
```

where *n* is a number between 0 and 7. To select the network printer, set *n*=4.

For further information on these and other configuration settings see the appropriate user guide.

Setting network numbers on an Acorn bridge



This adjustment must only be carried out by a technically-competent person who observes all due precautions. Parts of the exposed wiring and components will have hazardous voltages present when energised.

Before attempting to remove the casing of the equipment, switch off the equipment, and remove the power lead from the mains socket.

To join two network segments with a bridge, it is first necessary to assign a unique number to each segment. This may be in the range 1 to 127.

To change the link settings, you first have to remove the lid of the bridge; please refer to the *User Guide* for further details and safety precautions.

Inside the bridge box you can see the two rows of links used to set the network identities.

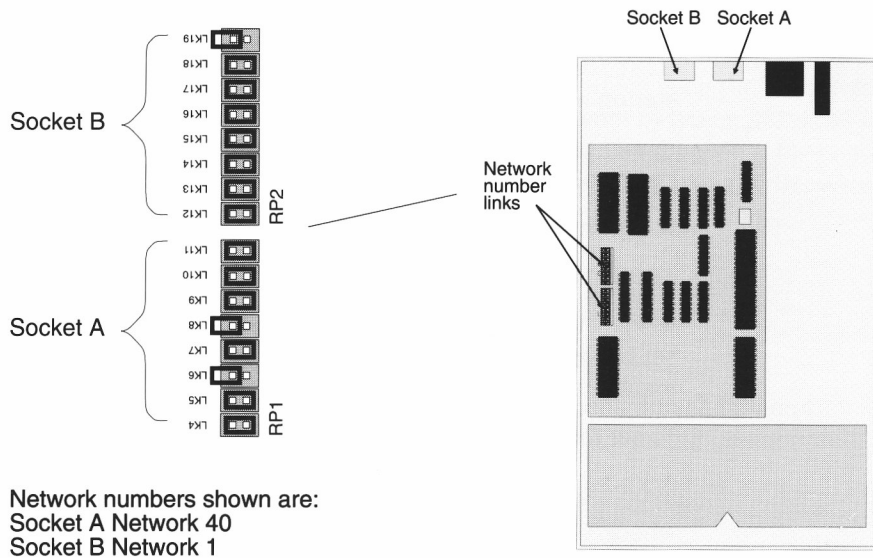

Figure 12.4: Network links on an Acorn Bridge.

The row next to the component marked RP2 controls the identity of the network segment plugged into socket A; the links next to RP1 determine the identity of the network segment plugged into socket B.

The least significant bit of the eight-bit network segment identity is at the top of the row, the most significant bit is the bottom link. If a link is made, the bit is zero; an unmade link implies a 1 bit. Never attempt to set a net number of less than 1. The bridge in the diagram has been set up between networks one and forty.

Note that all bridges connected to a numbered network segment should have the network identity set to the same number. Conversely, no two networks in a system connected by bridges may have the same network identity. Remember to keep a note of your settings.

Once the network identities have been set up on the PCB, the network segments may be joined. You do this by attaching the bridge box to network A by running a Econet lead from a socket or terminator box on the network to a socket marked A on the bridge box. Repeating for network B completes the joining process. Do not cross the cables over.

Label each net outlet at the bridge and label the bridge sockets with the network identities.

When you switch the bridge on, its software detects which networks are in the system and begins its task of looking for messages to pass between the two networks it bridges. Of the 8K of RAM in the bridge, between 4 and 6K is available for buffering transactions between the two networks.

There is a test button on the bottom of the Bridge box. Do **not** press this button while the bridge is connected to Econet, as it creates traffic which will jam the network. (See *Testing an Acorn bridge* on page 84 for more information about the test button.)

13

Expanding existing Econet networks

If you intend to expand an Econet network, you must plan your expansion carefully before starting. If a network expansion is badly planned, designed or installed, the network's performance will suffer. This chapter provides some common examples of network expansion.

Planning network expansion

When you expand a network

- limit the number of machines on each network to a workable number. (This is dependant upon machine type and network use, and will vary from network to network. Refer to the chapter *Planning the network* on page 5 for more details.)
- use a backbone wherever possible, and limit the machines fitted directly to the backbone to file servers and/or a management machine if possible.
- avoid placing client machines on a backbone.
- only add loops to an existing networks, or add further networks which are linked using Econet Bridges.
- **never** add a spur to a network.
- keep cable runs as short as possible.
- keep within the 500m, end to end, limit for each network segment.
- minimise the number of joins in the cable.

Consider expanding the network shown in *Figure 13.1: Required network expansion*. The network is next door to a room where a further six machines are to be installed. These machines need to be connected to the network so that they can access the file server and printer server. The network is 200m long, so the new machines can be added without the need to add a second network segment.

The outline symbols show the position of the new machines.

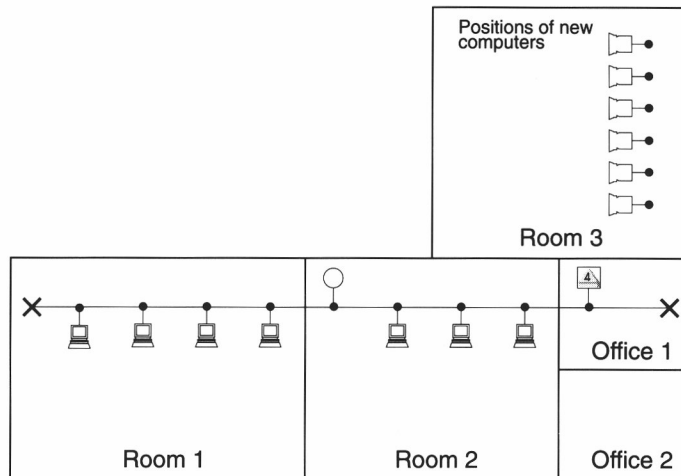

Figure 13.1: Required network expansion

There are two possible expansion routes available. The suggested expansion route is shown in Figure 13.2: Preferred expansion route. This route minimises the number of breaks in the cable and keeps the cable run as short as possible, making the network more reliable. As you can see, expansion simply involves moving the terminator and adding a further piece of cable.

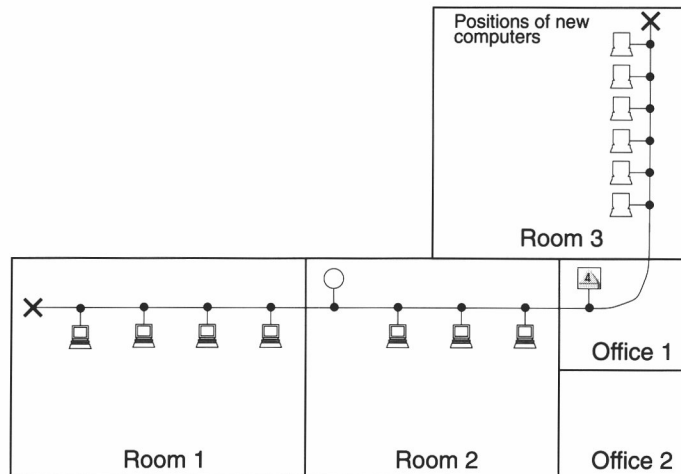

Figure 13.2: Preferred expansion route

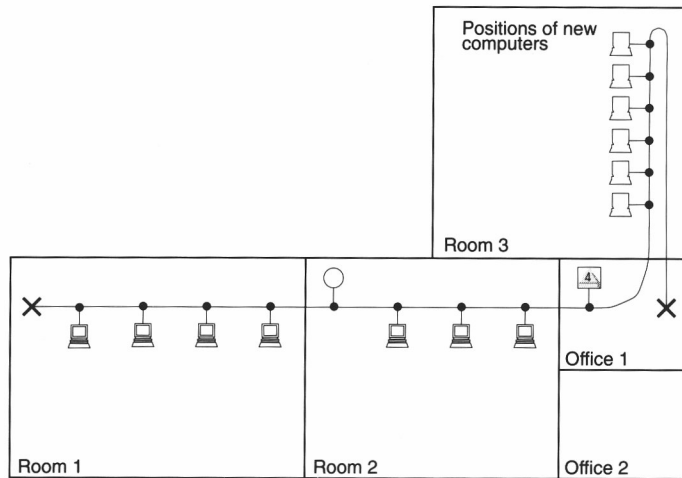

Figure 13.3: Inappropriate expansion route

If you take the expansion of this site further, adding a computer in each office, then this solution is your preferred option:

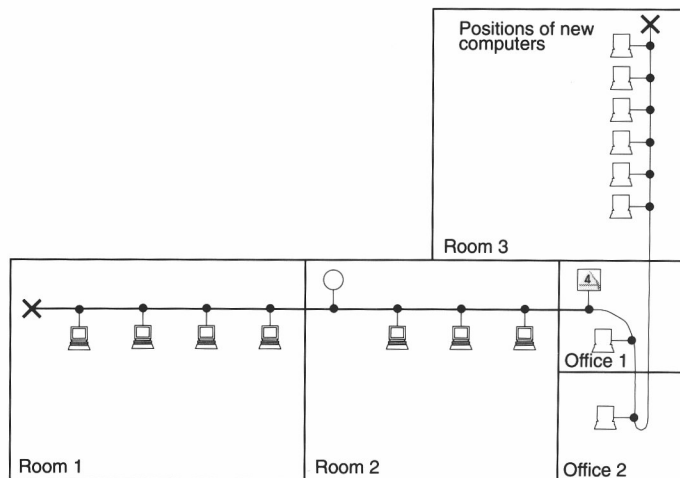

Figure 13.4: Further expansion of the network

You can see that this involves breaking the network and inserting a loop which ensures that the single cable topology is maintained. Under no circumstances should a spur be added.

Never expand a network without considering the overall layout.

Linking buildings



You should not work on any installation to link buildings while there is any likelihood of an inter-building section of the cable being struck by lightning.

All external wiring should be buried below ground level, and should be routed through conduit to allow for maintenance. Check the cable sheath for tears or cuts, and use self-amalgamating tape to repair.

Cables above ground are susceptible to electrical interference and are more prone to attract electrical discharges. Note that wiring regulations may forbid the use of overhead cables without appropriate precautions, such as wire supports.

If the distance to be covered is more than a few metres, the link should be set up as a separate network segment, with a bridge at either end, and the clock within a building at either end of the link.

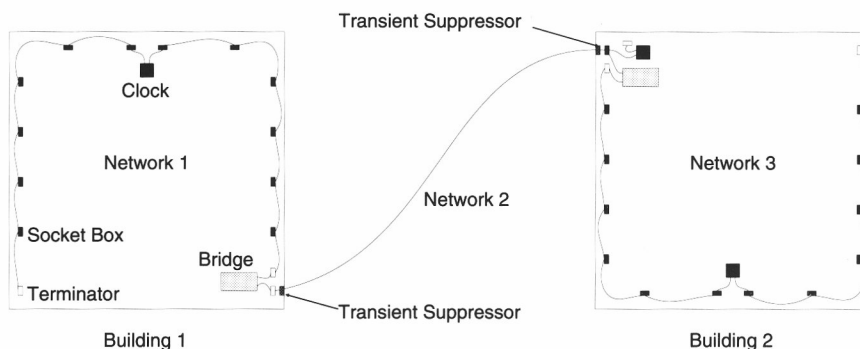

Figure 13.5: External links between buildings

Terminators should also be attached at either end in the normal way, and the inclusion of SJ Research transient suppressors is recommended. If only the two bridges (no stations) are connected directly to the link, this method normally gives reliable operation over distances of up to one kilometre, although the clock speed must be considerably reduced to achieve this.

Crossing obstacles

Where it is necessary to cross a public road, or other obstacle, it may not be possible to install your own pipe or conduit. In some cases you may find a conduit which already exists which you could use to install the cable.

As an alternative, it may be possible to hire lines from the telephone company or other authority that already has links between the two sites. In this case, you will need two twisted pair cable pairs for each Econet link. British Telecom, for example, may be able to provide such a link in the form of a pair of EPS8 lines. It must be stressed that the lines should link the two sites directly and not go via any public or private exchange or switching system.

Once you have access to the cable, you use one twisted pair circuit to carry the Econet clock signal and one pair to carry the data signals. The circuit provided may then be used to set up a network in the way described above.

As you will not be in a position to guarantee the quality of the cable in the link, you should connect each end to a bridge unit, and not attach any stations directly to the line. The link should be made as short as possible and terminated in the usual way.

Other types of link

Econet networks can be installed on remote sites using circuits conforming to the specifications of X21. Such circuits can be used to provide communication over several miles. For this, you will need two modified Econet bridges, and a cable operating at 64000 baud or above; the BT Kilostream is able to meet these requirements.

Acorn Customer Support are able to advise you on the installation of such links. Alternatively, you may wish to explore the benefits of Acorn Universal Networking (AUN). Again, Acorn Customer Support will be happy to help you with this.

Appendix A: Error messages on client terminals

The syntax of error messages may vary between the different machines, but messages usually provide sufficient information for the error message to be cross referenced here. Appropriate diagnostic techniques, are included where applicable.

No clock

Possible cause	Solution
The station is not plugged into the network.	Plug the machine into the network.
The Econet lead is faulty.	Replace the lead between the station and its socket box with a known good one.
The clock box is not plugged into the mains.	Check the mains socket switch, the clock box power switch and the connections.
The clock box is not plugged into the network.	Check the two 5-pin DIN plugs connecting the Econet cable to the clock box.
An open circuit or short circuit exists in the clock lines.	Repeat the tests detailed in the chapter <i>Testing the network</i> on page 75. Remember to test both sides of the clock as the line drivers may be damaged.
The clock box is faulty.	Consult your supplier.

Clock distribution faults

If the main network cable is below the specification recommended by Acorn, errors may occur even if the clock is set correctly and the clock box is fault free.

Line jammed

This is caused by continuous data signals on the data line preventing any station from using the network and is an indication that the Econet voltages are incorrect or not present.

Carry out the following, rebooting the local station at each stage to see if the error is still present:

- Reset all stations on the network, including any file servers. When resetting file servers, observe the normal precautions, and refer to the relevant file server manual if in any doubt.
- Disconnect all stations from the network. Ensure that this is done at the socket box and not at the machine, in case there are faults on the Econet lead.
- Check for faulty terminators; check particularly that the voltages are at the correct level as stated in the chapter *Testing the network* on page 75.
- Check for crossed wires (Data + and Data -).
- Check for a faulty Econet interface in a local station. Replace stations one at a time, and test for the voltages on the Data lines as described in the chapter *Testing the network* on page 75.

Not listening

This occurs when a message sent to a remote station is not accepted. The possible causes are:

Possible cause	Solution
The wrong station identity was given for the remote station.	
The remote station is not plugged into the network.	
The Econet station lead on the local or the remote machine is faulty.	Test and replace as appropriate.
The remote station does not have the network software present.	
The hardware or software in the local or the remote machine has entered an infinite loop.	Reset both machines.
The network is very heavily loaded.	Wait and try again later.
There is a hardware fault in either the local or remote station.	
There are two stations with the same Econet station number.	Check and reset as required.

Attempt a `Notify` between 2 stations. If this fails test the Econet cable as outlined in the chapter *Testing the network* on page 75. Do not attempt to notify the file server, as this will not work.

No reply

This indicates that the remote station has received a network request, but has not provided the expected reply within a suitable time. This fault may indicate that a peripheral (such as the drive or printer) on the remote station is faulty or not available.

These type of faults normally affect only file servers and printer servers.

- The network may be very heavily loaded; wait and try again later.
- For a printer server fault, check that the printer is switched on and is on line.
- For a file server fault, check that:
 - the discs on that file server are correctly inserted in the drives
 - the drives are connected and switched on
 - the SCSI drives are correctly terminated.
- For a RISC OS remote station, check that:
 - there is no error message box open on the remote machine
 - F12 has not been pressed
 - a non multi-tasking application is not running on the remote machine. (BBC Model B or single-tasking PC Emulator).
- Check that any other peripherals are switched on and are in a ready state. If the fault still occurs test the peripherals by using them locally. For example, try connecting a printer to a local station.

If these tests succeed, replace the user's local station and see if the fault persists. If it does, then check the installation cables, performing the tests detailed in the chapter *Testing the network* on page 75.

Net error or transmission error

This error is indicative of incorrect signals on the data or clock lines preventing a station from using the network and is an indication that the voltages are incorrect or not present.

- If the remote station is on a different network, attempt communicating with another station on the local network. If this works, move to the remote network and repeat the test. If no errors are apparent on either network, swap the bridge or have it repaired.
- Check for two stations with the same Econet station number. Reset as required.
- Check for faulty terminators, particularly that the voltages are at the correct level as stated in the chapter *Testing the network* on page 75.

- Check that there is only one clock active on the network. There may be more than one clock on the network if you have a FileStore, a new style Econet bridge, or an Econet interface which contains a clock. Remove the offending clock(s).
- Check that all the machines connected to the network are connected via the Econet socket. BBC Model Bs and Master 128s will generate this error if connected via the cassette port. Care should be taken that Archimedes machines have not been connected via MIDI interfaces or other such illegal network devices.
- Check for games software, some games cause this error if run on an Econet terminal.

Station not present or File server not found

This is usually generated when the particular remote station, file server or printer server etc, is not present on the network.

- Is the remote station on a different network? If so, re-try the communication specifying the correct name or network address.
- Has the default configuration been changed? If so, reconfigure the machine using the correct name or number.
- Is the network very heavily loaded? If so, wait and try again later.
- For a printer server fault, check that the printer is switched on and is on line.
- For a file server fault, check that:
 - the discs on that file server are correctly inserted in the drives
 - the drives are connected and switched on
 - the SCSI drives are correctly terminated.
- For a RISC OS remote station, check that:
 - there is no error message box open on the remote machine
 - F12 has not been pressed
 - a non multi-tasking application is not running on the remote machine (BBC Model B or single-tasking PC Emulator).
- Check that any other peripherals are switched on and are in a ready state.

If the fault still occurs, test the peripherals by using them locally. For example, try connecting a printer to a local station.

If these tests succeed, replace the users local station and see if the fault persists. If it does, then the installation cables, performing the tests detailed in the chapter *Testing the network* on page 75.

Appendix B: Econet file server error messages

This is a comprehensive list of all the Acorn file server error codes. These can be displayed either as `Internal Error #nn` on level 2 or 3 file servers, or by using the `*REPORT` or `*FSREPORT` facility on FileStore and Stacking FileStore servers.

A large number of the errors listed here are reported as a short string rather than the Hex number, such as those in the range `&A0` to `&A5`. However it is hoped that this list will prove useful when writing programs using the file server interface, and will provide a reference for the errors which are returned to a user as Hex numbers.

The list gives solutions to the errors where possible.

Key

INTERNAL	System software
RDBTMP	Read Bit Map
GETVEC	Get Vector
USRMAN	User Table Manager
AUTMAN	Authentication Manager
SRTMAN	Store Data Manager
MAPMAN	Map Manager
DIRMAN	Directory Manager
RNDMAN	Random Table Manager
SIN	System Internal Number
DSCMAN	Disc Manager
CMD PROC	Command Processor

Code	Description and fix	Area
01	Frame size is too big.	INTERNAL
02	(Entry) Function Code=0.	INTERNAL
03	(Entry) Unknown entry reason.	INTERNAL
04	(GETVEC) Size too big.	INTERNAL
05	(GETVEC) Insufficient space.	INTERNAL
06	(GETVEC) Size of store requested=0.	INTERNAL
07	(MODCOM) Can't get big buffer.	INTERNAL
08	(GETINT) Not a digit.	INTERNAL
09	Unable to open Receive Control Block. There is no Econet interface fitted in the unit or it is faulty. Solution: fit one or test file Server.	INTERNAL
0A	(RDBTMP) Read Bit Map error - Information is read from this by the file server so that it knows where each directory is and what it contains. Errors here prevent the file server from starting. Solution: Re-format and re-install from your backups.	INTERNAL
0B	Writing to sector zero. Usually caused by disc corruption. Solution: Archive information, reformat the Winchester, re-install the file server and restart.	INTERNAL
11	Unknown Machine.	INTERNAL
12	Too many users logged on.	INTERNAL
13	(USRMAN) User Manager utility. Restart called twice. Could be caused by system being re-started and is a system internal error. Solution: try switching off and re-starting.	USRMAN
14	Object not a directory.	INTERNAL
15	User not logged on. Solution: Log the user on.	
16	Number equals zero. A computer on the network has a station number of 0. Solution: Re-set the station number so that it is greater than 1.	USRMAN

Code	Description and fix	Area
21	Cannot find Password file. Password file has been deleted by some ill advised action - the file server will not start in this situation. Solution: Re-format the Winchester, re-install the file server and re-start. Can sometimes be cured by editing the Winchester, which is difficult and requires the level 3 file structure application note and a special program, see error 36. With FileStore use a floppy that has a password file on it or contact Acorn Customer Services for an application note explaining how to do this.	AUTMAN
22	User identifier not found	
23	Incorrect password	
24	Insufficient Privilege	
25	Bad password. Password does not start with a letter, or contains control characters.	
26	User ID already exists.	
27	Password file syntax error.	
28	Password file full.	
29	Object \$.PASSWORDS has wrong type, eg it is a directory. This is very similar to error 21. Solution: As 21 including the application note on Econet Level III file structure.	AUTMAN
31	STRMAN (Store Manager utility). Restart called twice and is a system internal error. Solution: Should try switching off and restarting.	STRMAN
32	SIN=0. Usual cause is a corrupted disc. Solution: Try re-installing and restarting system. This should not occur in version 1.06 of the Level 3 file server software. If you are using an older version you should contact Acorn Customer Services for details of how to upgrade.	STRMAN
33	REF COUNT = &FF Occurs when trying to open a file or dismount. This should not occur on the current versions of file server software 1.06 and above. If you are using an older version you should contact Acorn Customer Services for details of how to upgrade.	STRMAN

Code	Description and fix	Area
34	REF COUNT = &00 Occurs when trying to open a file or dismount. This should not occur on the current versions of file server software 1.06 and above. If you are using an older version you should contact Acorn Customer Services for details of how to upgrade.	STRMAN
35	Size of file too big or size = 0. Size of directory/file is larger/smaller than in cache. Caused by trying to create a file larger than 16 MBytes on a Winchester. Solution: try to restart, if persistent then re-install archives or re-install originals and re-start.	STRMAN
36	Invalid window address - Caused by people hacking the password file, the file server losing power while writing to the password file or a corruption in the \$ directory. Means password file has been increased by an invalid number of bytes i.e. 157, 250 etc. Solution: The size has to be an integral number of sectors long ie:- &100, &200, etc, however in the latest versions it is automatically increased as more passwords are entered. There is a program that will correct this problem. This is available on written request (please use headed paper) from Acorn Customer Services.	STRMAN
37	No free cache descriptors. Too many items already stored in the cache. Solution: restart to clear them out.	STRMAN
38	Window Ref Count > 0 - the information in the cache is marked with a reference count so that if, for example, one person opens a file and then another opens the same file this is stored in the cache and the ref count is updated twice. The above is generated when the cache hasn't been cleared of previous count of accesses or you try to create a new user with a username that doesn't start with a letter. Solution: Quit and restart file server.	STRMAN
39	Big buffer already in use.	
3A	Invalid buffer address.	
3B	Ref Count = &FF - as 33.	STRMAN
3C	Store deadlock!! - The cache is full. Caused by the directory structure becoming too complex to fit into the cache area. Solution: Re-start file server and reduce number of users logged on and in the password file. Reduce number of directories in \$ directory.	STRMAN

Code	Description and fix	Area
3D	Arithmetic Overflow in TSTGAP TSTGAP is a check that is run on the cache and has found incorrect amount of space. Solution: Restart the file server.	STRMAN
41	CDIR too big (Create Directory) Trying to create a directory that is too large, the maximum amount of space for a directory is 19 Sectors with 255 entries per directory. Solution: Reduce specified size of new directory.	DIRMAN
42	Broken Directory. Usually caused by loss of power while writing to the Winchester. Solution: Re-initialise. This could be cured by editing the Winchester; this requires a high level of experience and also the application note on Econet Level III file server structure.	DIRMAN
43	Object not found.	
44	Object not a directory.	
45	Insufficient access. Object does not have read access set. Solution: Set read access.	
46	Wrong arguments to Set/Read Object Attributes. This is generated when using OSARGS to READ/WRITE an open files attributes ie: X points to 4 locations in zero page Y contains the file handle A specifies the type of operation. (See page 37 in Econet System User Guide) Solution: Redefine argument.	DIRMAN
47	Directory entry locked.	
49	Object in use (i.e. open).	
4A	Directory not empty. Usually occurs when trying to delete a directory that contains entries.	
4B	Types do not match.	
4C	No Write Access. Access on file/directory is Read only Solution: Change access or you will not be able to write to it.	DIRMAN
4D	Maximum directory size reached.	

Code	Description and fix	Area
4E	Client asks for too many entries. When cataloguing the ANFS/NFS requests information on the files in the directory, the transmitting machine sends too many for the receiver to fit into its buffer. Solution: Start again or update ANFS/NFS software.	DIRMAN
4F	Bad Arg. To Examine - similar to 46.	DIRMAN
51	Disc number not found.	
52	Disc space exhausted.	
53	SIN (System Internal Number) not for start of chain. This occurs when the file server is searching for a file. When it reaches the location it finds that it is not at the beginning of the file. Solution: If possible stop and restart the system. If it is a file you should be able to rename it ie: ZZZZZ so that you don't use it. If it is a directory use backups to re-install. Failing this, reformat, re-initialise and re-install.	MAPMAN
54	Disc not a file server disc. Could be a corrupted disc. Solution: Put valid file server disc in.	MAPMAN
55	Level II only. Both sector maps corrupt. Sector maps are on both sides of the disc and update with information with regard to updating, reading and writing to or from files. This information is usually also stored in the cache which updates the sector map as and when it has changed. If only one end of a sector map becomes updated and the system crashes, you can still use the disc as the sector map on the other side is correct for the previous state. If both maps on both sides have become corrupt (highly unlikely) then you will have to resort to backups (see also 57).	MAPMAN
56	Illegal drive number. This means that the initialisation routines differ from the input drive numbers. Solution: Restart file server.	MAPMAN
57	Level II and FileStore only Map sequence numbers differ by >1. This should not differ unless a corruption occurs half way through updating the sector map in which case the sequence numbers could differ by > 1. Solution: Refer to backups.	MAPMAN
58	Illegal Object size (=0) The size specified by user cannot be accepted, ie 0. Solution: Enter correct or acceptable size.	MAPMAN

Code	Description and fix	Area
59	Level II only. New map doesn't fit in old space. On start-up of the file server it asks "how many discs" and allocates memory for 1-2 maps and the remainder of memory to the Cache. This means that too large a disc has been inserted ie: if you usually use 1 x 40 track single-sided and have inserted an 80 track double-sided disc. It can support up to 80 track double-sided. Solution: Insert correct size disc.	MAPMAN
5A	Level II and FileStore only. Disc of same name already in use! Solution: Remove disc and change its name, or insert the correct disc.	MAPMAN
5B	No more space in Map descriptors. The area in the cache that contains the information that the path name accesses to find various files / directories is full. Solution: Restart file server.	MAPMAN
5C	Insufficient user free space. Solution: User must delete old user space to make room. Alternatively use the *SETFREE utility to increase the free space for the user.	MAPMAN
61	RNDMAN restart called twice. This could be caused because the system has been re-started incorrectly. Solution: Should try switching off and restarting again.	MAPMAN
62	Invalid handle.	
63	Handle quota exhausted.	
64	Handle table full. This is managed by the file server and monitors the users, what they are doing, accessing etc. The maximum number of handles that the file server can cope with at once is 255 and each user can have up to 8. These are normally allocated as library, Currently Selected Directory, the Root Directory and 5 open objects.	RNDMAN
65	Object not open. Solution: Open object then retry.	
66	Copy not for file objects. This is a system internal error meaning the system cannot copy the file handles.	RNDMAN
67	Random table full. There are too many objects open for the file server to handle. Solution: Ask all users to log off, then increase number of users that can log on.	RNDMAN

Code	Description and fix	Area
68	File already open (interlock).	
69	Object not a file. You are trying to load a filename which is a directory. Solution: Recall correctly.	RNDMAN
6A	End of file on reading.	
6B	Insufficient access on opening a file for reading or writing	
6C	Attempt to point outside of current file.	
6D	Invalid argument to RDSTAR. This means that the wrong sort of data has been sent to the file server. Solution: Re-send in correct form.	RNDMAN
6E	Object not open for update. Solution: Close object then re-open for update.	
6F	GETBYTE trying to read a byte after the last byte in the file.	
71	Invalid number of sectors. This is very low level. Solution: Re-format, re-initialise the file server and re-install from your backups.	DSCMAN
72	Store address overflow.	DSCMAN
73	Accessing beyond end of file.	DSCMAN
74	Invalid SIN (protected area). This is very low level and means that the map is being overwritten Solution: check address.	DSCMAN
75	Disc protected.	
76	Disc error (not disc protected).	
83	Too much data sent from client. Blocks of data sent are too big. Solution: Should use SAVE procedures in NFS/ANFS.	CMD PROC
84	Wait times out. This is an internal error where the receiving terminal is still waiting for data not sent. A hardware fault may be the problem. Solution: Re-send. If this fails check hardware.	CMD PROC

Code	Description and fix	Area
85	Invalid function code. The function codes are command codes 0-32 at present, user is utilising an unallocated code. Solution: Check you are using the correct code!	CMD PROC
87	Bad *ACCESS string. Solution: Use the correct access string.	
89	Bad file title (mismatched quotes).	CMD PROC
8A	File too big, i.e. over 16Mbytes. Usually caused by bad arithmetic in PTR# values. Solution: Delete file.	CMD PROC
8C	Bad privilege letter. This occurs when using an incorrect letter when setting the access. Solution: Use W, R, L	CMD PROC
8D	Excess data in PUTbytes. As 83.	CMD PROC
8E	Bad information argument. This is caused by incorrect argument information request. Solution: Change format of info call.	CMD PROC
8F	Bad argument to RDAR (Read Object Information). The file server does not understand the input information.	CMD PROC
90	Bad date and time. Solution: Change date and time using \$.Utils.SETTIME.	CMD PROC
A0	Line jammed. This error is returned if there is continuous information on the data lines. This may be due to a fault in another station or one of the terminators.	
A1	Net error. This is returned if an error occurs during transmission. Usually caused by two machines with the same station number, or a fault in the cabling.	
A2	Not listening. Means the machine to which the command was directed is not connected or unavailable.	
A3	No Clock. This is returned if the Econet interface cannot find a valid clock signal.	
A4	Bad transmit block. Indicates that the transmit block used was of an incorrect format.	

Code	Description and fix	Area
A5	<p>No reply. Usually means that some operation has failed whilst communicating with another station. Solution: Retry and if fault persists refer to <i>Appendix A: Error messages on client terminals</i>.</p>	
AC	<p>Bad user name in Password file. This is generated usually by a corruption on a user name that is not being recognised. Solution: If a backup has been taken then copy onto the file server otherwise reformat, re-initialise and re-install.</p>	AUTMAN
AE	<p>User not logged on. Solution: Log on using *I AM <User name></p>	USRMAN
AF	<p>Types don't match. Usually occurs when trying to save a file over a directory or vice versa. Solution: Check names of files and directories, and change accordingly.</p>	DIRMAN
B0	<p>Renaming across two discs. Files cannot be renamed across two discs, use copy instead.</p>	CMD PROC
B1	<p>UserID already in Password file. Occurs when trying to set up a User identical to one named and recognised in Password file. Solution: Check UserIDs already in use and utilise a different one.</p>	AUTMAN
B2	<p>Password file full. This will not occur if you are using version 1.06 or greater of the file server software as current versions of the file server software automatically extend the passwords file until a maximum size of 64K (2097 users) is reached.</p>	AUTMAN
B3	<p>Maximum directory size reached. The directories are 19 entries (2 sectors) by default, and will extend automatically until 255 entries has been reached. Solution: Split directories or delete old entries.</p>	DIRMAN
B4	<p>Directory not empty. This will usually occur when trying to delete an entire directory. Solution: User will have to delete the directory contents, ie: files, before deleting the directory itself.</p>	DIRMAN
B5	<p>Trying to load a directory.</p>	CMD PROC

Code	Description and fix	Area
B6	Disc error on map read/write. This indicates a corruption on the disc. Solution: Try restarting the file server. If this fails reformat, re-initialise and re-install.	MAPMAN
B7	Attempt to point outside file. The file pointer has moved outside the perimeter which it can use to extend the file.	RNDMAN
B8	USRTB Full (User Table full). Too many users. Solution: Start with a larger number of users allocated or shutdown and log an existing user off the network	USRMAN
B9	Syntax error in password. The method used to log on has been incorrectly expressed Solution: Try again	AUTMAN
BA	Insufficient privilege. This is generated if a user is trying to execute a command which can only be used by system privileged users. Solution: Ask network manager to access it for you.	AUTMAN
BB	Incorrect Password. Solution: Try again with correct password.	AUTMAN
BC	UserID not found in Password file. The User is not recognised. Solution: Enter the required UserID or check that the one being used is correct.	AUTMAN
BD	Insufficient Access. As BA.	DIRMAN CMD PROC RNDMAN
BE	Object not a directory. The specified object is a file not a directory. Solution: Re-specify checking criteria.	DIRMAN
BF	The machine number is not in the file servers user table. The terminal identification number is not recognised by the user table. Solution: Log on to the file server.	USRMAN
C0	Handle quota exhausted (too many open files). Solution: Log off some users or restart file server specifying more users up to the maximum of 80.	RNDMAN

Code	Description and fix	Area
C1	File not open for update. File access has been set so that it is read only or OPENIN has been used. Solution: Alter access or use OPENUP	RNDMAN
C2	Object in use (ie: open) This usually occurs when a user has opened a file to read and, for example, another user wishes to delete it. Also reported as 'File already open'.	DIRMAN
C3	Dir entry locked. The directory that the user wishes to delete is Locked. Solution: Use *Access to unlock it.	DIRMAN
C6	Disc Space exhausted. No more free space on disc. Solution: Delete unused files.	MAPMAN
C7	Unrecoverable disc error. Solution: Re-format, re-initialise and re-install from your backups.	DSCMAN
C8	Level II only. Disc number not found. This would be generated if incorrect disc number was used or the size was incorrect.	MAPMAN
C9	Disc protected. There is write protection on the disc that the user is trying to copy or save to. Solution: Remove protection.	DSCMAN
CC	Invalid separator in file title. Indicates that there are illegal characters in the file name.	DIRMAN
CF	Invalid access string. Solution: Redefine the access string correctly.	CMD PROC
D4	File write only. User is trying to read or delete a file that has the access set to write only or the file is not open for input.	RNDMAN
D5	Object not found. Occurs when the name of a directory or file is not found.	DIRMAN
D6	Disc name not found. This error would occur with SDISC when changing discs. Would usually be generated when the Map Manager cannot recognise the disc that has been inserted. Solution: Change disc and verify it to check that there is no corruption on the disc.	MAPMAN

Code	Description and fix	Area
DE	Invalid handle or channel error. This will occur if the memory used as workspace by the NFS/ANFS is corrupted. This can occur if the machine is switched off and then on again while logged on or, on a BBC Model B, if the value of page is changed to &E00.	RNDMAN
DF	End of file.	RNDMAN
F5	Internal bit map cache error.	
F6	Cached bit map holds no free sectors.	
F8	Write error (data read <> data written).	
F9	Attempting to zero an illegal amount of disc.	
FA	Multiple block allocate fails.	
FC	Single block allocate fails.	
FD	Bad file name, string etc.	
FE	Bad command.	

ADFS errors

Error N°.	Meaning	Cause
00	No sense	1
01	No index signal	1
02	No seek complete	1
03	Write fault	1
04	Drive not ready	1
06	No track	1
10	ID CRC error	5, 6
11	Uncorrectable data error	5, 6
12	ID address mark not found	1, 5, 6
13	Data address mark not found	5, 6
14	Record not found	5, 6
15	Seek error	5, 6
16	Not assigned	5, 6
17	Not assigned	5, 6
18	Data check in no retry mode	5, 6
19	ECC error during verify	5, 6
1A	Interleave error	5, 6
1B	Not assigned	5, 6
1C	Unformatted drive	1, 5, 6
1D	Self test failed	4
1E	Defective track	5
1F	Not assigned	8
20	Invalid command	2, 3, 7
21	Illegal block address	2, 3, 7
22	Not assigned	2, 3, 7
23	Volume overflow	2, 3, 7

Error Nº.	Meaning	Cause
24	Bad argument	2, 3, 7
25	Invalid logical unit number	2, 3, 7
26 to 2F	Not assigned	2, 3, 7

Key to causes

- 1 Cables between drive and Adaptec Controller
- 2 Cables between Adaptec and Host or Host and I/O
- 3 Host Adaptor
- 4 Adaptec Controller
- 5 Winchester Drive unit
- 6 Power supply unit
- 7 Filing system ROM or application program
- 8 Any of the above

These error codes will appear on the screen of a level 2 or 3 file server screen in the form `Disc Error xx at nn nnnn nnnn`. These errors are also valid for FileStore, but are not reported in the same way.

Disc errors are reported as internal errors, obtained using `*REPORT` or `*FSREPORT`.

If you think you have a fatal Winchester error, i.e. the E20 is not being recognised by the E01, then plug the E20 on to the 1Mhz bus of a BBC Master 128 computer and run the ADFS verify on it. This will report any fatal errors.

For more details see the *ADFS user guide*, *Winchester disc user guide* and the *Acorn Winchester disc service manual*.

Appendix C: About NETMON

A network monitor program called NETMON is supplied on Acorn file servers for use with BBC Model B, BBC Master 128 and BBC Master Compact machines. NETMON enables the system manager to breakdown the network traffic, to identify which stations are using the network, and which, if any, are failing to communicate correctly with another station.

The four-way handshake

Data is transferred during Econet TRANSMIT operations in which four bundles of data (called packets or frames) are exchanged. The data exchange operation is known as a four-way handshake, and while it is taking place, no-one else can use the network:

- 1 the source station sends out an "Are you there?" frame, called a scout
- 2 the destination station sends back an acknowledgement
- 3 the source station sends its data
- 4 the destination station returns a final acknowledgement.

The handshake ensures that a transmitter can tell for certain whether its message had been successfully received; if the final acknowledgement arrives, the data must have reached its destination.

The scout frame is ten bytes long, and is arranged like this:

1 byte	2 bytes	2 bytes	1 byte	1 byte	2 bytes	1 byte
flag station	destination station	source byte	control byte	port	CRC	flag

The opening and closing flags mark the beginning and end of the frame, and always contain 01111110. Information about the destination and source stations is held in each case as a pair of bytes; the first of the pair contains the station number itself. The CRC is a 16-bit cyclic redundancy check, the result of a calculation carried out on all the bits (except the flags and any inserted zeros) in the frame.

The destination station then compares the scout with its open RECEIVE control blocks, to try to find a match. While the search takes place, it sends out a stream of flags to prevent other stations from claiming the line; a process is called flag fill.

When the destination station finds a match, it stops the flag fill and sends an acknowledgement in a frame eight bytes long, arranged like this:

1 byte	2 bytes	2 bytes	2 bytes	1 byte
flag	destination station	source station	CRC	flag

Once it receives this acknowledgement frame, the transmitting station begins to send its data. The length of the data frame depends on the size of the data; its arrangement is like this:

1 byte	2 bytes	2 bytes		2 bytes	1 byte
flag	destination station	source station	data	CRC	flag

Finally, and as long as the transfer was successful, the receiving station sends its second acknowledgement, identical in form to the first.

If the final acknowledgement does not get through, the transmitter cannot be sure whether the data was received or not. In some applications, it may be risky to re-transmit, because the receiving station might, at the end of the process, have two sets of identical data. This problem is characteristic of the four-way handshake protocol, and the solution is to identify each transmission with a number, either in the data itself or in the control byte, so that the receiver can distinguish between a re-transmission and a new transmission.

Running NETMON

The NETMON utility enables you to see frames on the screen, making it easy, for example, to find out what has gone wrong when a transmission fails.

The program is run by typing the following commands:

For BBC Model B machines use:

```
*Run $.Library.NETMON
```

For BBC Master 128 and BBC Master Compacts use:

*Run \$.Library1.NETMON

A message like this appears:

Screen: ECONET MONITOR 001

1E

From now on, every communication on the network will show up on your screen.

In this example, a user at station 189 *DELETes a file.

FE00BD0080v99 BD00FEv00 FE00BD00900001020444454C455445v0D BD00FEv00 i

BD00FE0080v90 FE00BDv00 BD00FE0000v00 FE00BDv00 i



The process involves two four-way handshakes. The four frames in each handshake are arranged horizontally: scout, acknowledgement, data, acknowledgement. In each frame, the flags and the CRC are not shown. The *i* at the end of each line shows that the network is, at that point, idle.

From this screen display, you can see immediately the contents of each frame. For example, the first scout shown contains:

1 byte	2 bytes	2 bytes	1 byte	1 byte	2 bytes	1 byte
flag	destination station	source station	control byte	port byte	CRC	flag
	FE 00	BD 00	80	99		

FE is the file server number, 254 in decimal, and BD is the station number, 189. The *v* character shows that the frame had been checked, using the CRC, and is valid.

To make the screen easy to read, the program:

- shows a space between each frame
- starts a new line after every *i*
- truncates long data frames.

The monitor facility is useful for checking up on transmission failures. This screen, for example, shows a scout frame that has received no acknowledgement:

FE00BD0080v99 i

The result of this would be a &42 error.

In the following example, station 189 has tried to send station 1 more data than its buffer was set up to receive:

```
0100BD0080v99 BD0001v00 0100BD00AABBCCb i
```

The four-way handshake has been aborted in the middle of the data packet. The `b` indicates an aborted handshake.

Apart from `i`, `v` and `b`, three other status letters can appear:

- e CRC check has failed, because of noise on the network or electrical interference
- d the data carrier detect input to the 68B54 has changed; probably, no clock signal is being received
- o overrun: the network is running too fast for the monitor.

When you become experienced with using NETMON you will gain a feel for what constitutes a good network monitor output. You don't actually need to study the output in detail; you just need to know what you're looking for.

To pause NETMON output to prevent it scrolling off the screen before it can be read, use *Control-Shift*.

Example NETMON outputs

The following data illustrates the network traffic on a good network.

```
Econet Monitor 099
i
5D01330081vD2 33005Dv01 5D013300450000840A1100001E11BFFF88AA40v52 33005Dv01 i
33005D0181vD2 5D0133v00 33005D014500007C40B40000FE11A96388AA81vA1 5D0133v00 i
8C00FB0080v96 FB008Cv00 8C00FB0000002000000000000000F2040030v00 FB008Cv00 i
FFFF5F03809F4E415659202001v00 i
FFFF6C03809F4E415659482001v00 i
FFFF6C03809F4E415659482001v00 i
5D01330081vD2 33005Dv01 5D013300450000840A1D00001E11BFF388AA40v52 33005Dv01 i
33005D0181vD2 5D0133v00 33005D014500007C4CDD0000FE119D3A88AA81vA1 5D0133v00 i
FFFF6C03809F4E415659482001v00 i
5D01330081vD2 33005Dv01 5D013300450000900A1F00001E11BFE588AA40v00 33005Dv01 i
33005D0181vD2 5D0133v00 33005D014500009C4E770000FE119B8088AA81v50 5D0133v00 i
5D01330081vD2 33005Dv01 5D013300450000840A2000001E11BFF088AA40v52 33005Dv01 i
33005D0181vD2 5D0133v00 33005D014500007C4EFF0000FE119B1888AA81vA1 5D0133v00 i
FFFF9C0D809F4359414E202001v00 i
FFFF960080D863633030322E31v37 i
9600B800D8vD8 B80096v00 9600B80063633939636339v39 B80096v00 i
96006D10D8vD8 i
96001400D8vD8 i
96006203D8vD8 i
96007B06D8vD8 i
9600B110D8vD8 i
5D01330081vD2 33005Dv01 5D013300450000900A2200001E11BFE288AA40v00 33005Dv01 i
FFFF2B2B809F57484954452001v00 i
FFFF9C0D809F4359414E202001v00 i
FFFF2B2B809F57484954452001v00 i
5D01330081vD2 33005Dv01 5D013300450000840A2300001E11BFED88AA40v52 33005Dv01 i
33005D0181vD2 5D0133v00 33005D014500007C50E80000FE11992F88AA81vA1 5D0133v00 i
FFFFFC10809F48415A454C2001v00 i
5D01330081vD2 33005Dv01 5D013300450000900A2500001E11BFD88AA40v00 33005Dv01 i
FFFF5206809F494E4449474F01v00 i
33005D0181vD2 5D0133v00 33005D014500009C535F0000FE11969888AA81v50 5D0133v00 i
FFFFBE00809F42454947452001v00 i
5D01330081vD2 33005Dv01 5D013300450000840A2600001E11BFEA88AA40v52 33005Dv01 i
33005D0181vD2 5D0133v00 33005D014500007C54130000FE11960488AA81vA1 5D0133v00 i
FFFFB505809F4F52414E474501v00 i
5D01330081vD2 33005Dv01 5D013300450000900A2800001E11BFDC88AA40v00 33005Dv01 i
33005D0181vD2 5D0133v00 33005D014500009C58250000FE1191D288AA81v50 5D0133v00 i
```

Minor transmission problems normally show at the end of the largest data block, so this is the first place to look. Note that although a packet may have failed for some reason there is often an acknowledgement from the receiving station. The following output indicates this. Errors appear in the same column, and are shown in bold text:

```
Econet Monitor 099
i
5D01330081vD2 33005Dv01 5D013300450000840A1100001E11BFFF88AA40v52 33005Dv01 i
33005D0181vD2 5D0133v00 33005D014500007C40B40000FE11A96388AA81vA1 5D0133v00 i
8C00FB0080v96 FB008Cv00 8C00FB0000002000000000000000F2040030v00 FB008Cv00 i
FFFF5F03809F4E415659202001v00 i
FFFF6C03809F4E415659482001v00 i
FFFF6C03809F4E415659482001v00 i
5D01330081vD2 33005Dv01 5D013300450000840A1D00001E11BFF388AA40v52 33005Dv01 i
33005D0181vD2 5D0133v00 33005D014500007C4CDD0000FE119D3A88AA81bA1 5D0133v00 i
FFFF6C03809F4E415659482001v00 i
5D01330081vD2 33005Dv01 5D013300450000900A1F00001E11BFE588AA40v00 33005Dv01 i
33005D0181vD2 5D0133v00 33005D014500009C4E770000FE119B8088AA81v50 5D0133v00 i
5D01330081vD2 33005Dv01 5D013300450000840A2000001E11BFF088AA40v52 33005Dv01 i
33005D0181vD2 5D0133v00 33005D014500007C4EFF0000FE119B1888AA81vA1 5D0133v00 i
FFFF9C0D809F4359414E202001v00 i
FFFF960080D863633030322E31v37 i
9600B800D8vD8 B80096v00 9600B80063633939636339v39 B80096v00 i
96006D10D8vD8 i
96001400D8vD8 i
96006203D8vD8 i
96007B06D8vD8 i
9600B110D8vD8 i
5D01330081vD2 33005Dv01 5D013300450000900A2200001E11BFE288AA40v00 33005Dv01 i
FFFF2B2B809F57484954452001v00 i
FFFF9C0D809F4359414E202001v00 i
FFFF2B2B809F57484954452001v00 i
5D01330081vD2 33005Dv01 5D013300450000840A2300001E11BFED88AA40b52 33005Dv01 i
33005D0181vD2 5D0133v00 33005D014500007C50E80000FE11992F88AA81vA1 5D0133v00 i
FFFFFC10809F48415A454C2001v00 i
5D01330081vD2 33005Dv01 5D013300450000900A2500001E11BFDF88AA40v00 33005Dv01 i
FFFF5206809F494E4449474F01v00 i
33005D0181vD2 5D0133v00 33005D014500009C535F0000FE11969888AA81v50 5D0133v00 i
FFFFBE00809F42454947452001v00 i
5D01330081vD2 33005Dv01 5D013300450000840A2600001E11BFEA88AA40v52 33005Dv01 i
33005D0181vD2 5D0133v00 33005D014500007C54130000FE11960488AA81bA1 5D0133v00 i
FFFFB505809F4F52414E474501v00 i
5D01330081vD2 33005Dv01 5D013300450000900A2800001E11BFDC88AA40v00 33005Dv01 i
33005D0181vD2 5D0133v00 33005D014500009C58250000FE1191D288AA81v50 5D0133v00 i
```

Some blocks of data are perfectly valid, yet do not conform to the four-way handshake style. These packets are special packets called broadcast packets, and are used when a machine is looking for information about shared resources such as bridges, file servers, or printer servers. The following packet is one such example:

```
FFFF2B2B809F57484954452001v00 i
```

The FFFF at the start of the data indicates that this is a broadcast packet.

Broadcast loader packets begin with FFFD. The structure and appearance of the data output looks quite different to that of ordinary network traffic:

```
FC00140080v99 1400FCv00 FC001400AC1203010105217373662E21737072v0D 1400FCv00 i
1400FC0080vAC FC0014v00 1400FC0000000142F9FFFFC546CBE8E40C000Dv00 FC0014v00 i
FC00140080v99 1400FCv00 FC001400AD1203010107217373662E21737072v0D 1400FCv00 i
1400FC0080vAD FC0014v00 1400FC00000001090A14001Av00 FC0014v00 i
FFFD140080D646A1C10888002210C40900v00 i
FC00140080v99 1400FCv00 FC001400AE060301010101217373662E217370v0D 1400FCv00 i
FFFD140080D646A1C10888002210C40900v00 i
1400FC0080vAE FC0014v00 1400FC000000v06 FC0014v00 i
FC00140080v99 1400FCv00 FC001400AF1203010105217373662E21737072v0D 1400FCv00 i
FFFD140080D646A1C10888002210C40900v00 i
1400FC0080vAF FC0014v00 1400FC0000000142F9FFFFC546CBE8E40C000Dv00 FC0014v00 i
FC00140080v99 1400FCv00 FC001400B00C03010106v01 1400FCv00 i
1400FC0080vB0 FC0014v00 1400FC000000E40Cv00 FC0014v00 i
FC00140080v99 1400FCv00 FC001400B10C03010106v02 1400FCv00 i
1400FC0080vB1 FC0014v00 1400FC000000000Ev00 FC0014v00 i
FC00140080v99 1400FCv00 FC001400B20AB305010600E40C000000v00 1400FCv00 i
1400FC0080vB2 FC0014v00 1400FC0000v00 FC0014v00 i
FFFD140080D646A1C10888002210C40900v00 i
1400FC0080vB3 FC0014v00 1400FC000700000010000000E80C0000800100vFF FC0014v00 i
1400FC0080vB3 FC0014v00 1400FC0088BCCBCCBBBCCBCCBCCBCCBBBCC88v99 FC0014v00 i
1400FC0080vB3 FC0014v00 1400FC000000449900EEEE0000EEEE000000CCv7A FC0014v00 i
1400FC0080vB2 FC0014v00 1400FC00000080E40C00v00 FC0014v00 i
FC00140080v99 1400FCv00 FC001400B407030501v06 1400FCv00 i
FFFD140080D646A1C10888002210C40900v00 i
1400FC0080vB4 FC0014v00 1400FC0000v00 FC0014v00 i
FC00140080v99 1400FCv00 FC001400B507030501v04 1400FCv00 i
1400FC0080vB5 FC0014v00 1400FC0000v00 FC0014v00 i
```

Quitting NETMON

To leave the monitor program press *Ctrl-Break*.

Appendix D: Software available on the Acorn Support BBS

Econet utilities may be downloaded from Acorn's Technical Support BBS, providing that you have access to the Schools' or Dealers' Closed User Groups.

If you don't know how to access BBS, or if you wish to find out more about it, please write to Acorn Customer Services, at Acorn Computer Limited. (For our full address and other details, please refer to *Appendix I: Useful addresses* on page 147)

You can register by calling from a modem, with your communications software set to ANSI and 8 data bits, No Parity and 1 stop bit at either 300/1200/75, 1200/1200 or 2400/2400 baud.

To download these programs simply select (D)ownload from the Filebase menu and enter the appropriate file name from the list below:

Archimedes Boot Sequences	NETBOOT
Archimedes SetStation	STATION
Archimedes SetFree	SETFREE
Archimedes Teletext terminal	TELETEXT
M128/Compact SetStation	MSETSTN
M128/Compact SetFree	MSETFREE
E20/E40/E60 Formatter (over Econet)	FSFORMAT
Recovering FileStore Password file	FSPWDREC
BigDelete	BIGDELETE
Level 3 file server	L3v1_06
SuperForm	SUPERFORM
Viewdata System Disc	VIEWDATA

Appendix E: Tools required

You may find the following equipment useful when you are installing an Econet network.

The tools and their order codes, were supplied by RS Components, although other suppliers could of course be used.

Order Code	Quantity	Description
555-651	1	Tool case
546-534	1	Supadrive screwdriver
544-702	1	Supadrive screwdriver
544-718	1	Supadrive screwdriver
544-689	1	Flat blade screwdriver
544-651	1	Flat blade screwdriver
544-639	1	Flat blade screwdriver
547-470	1	Cable cutters
544-544	1	Wire strippers
544-487	1	Side cutters
544-386	1	Side cutters
544-415	1	Snipe nose pliers
546-742	1	Stanley knife
545-171	1	Tweezers
547-997	1	Adjustable spanner
545-159	1	Hacksaw
545-092	10	Hacksaw blades
546-556	1	Hammer
604-444	1	Measure
549-319	1	Dentist's mirror

Order Code	Quantity	Description
546-988	1	Pliers
547-565	1	Soldering iron
547-739	1	Spare bits
615-387	1	Stand
567-856	1	Solder 250g
614-615	1	Multimeter
470-128	1	IDC tool
547-442	1	Cable stripper
549-757	1pk	Brush
549-763	1pk	Brush
399-906	10	Heat shrink
399-940	10	Heat shrink
480-642	6	Joining box
	1	Cordless electric drill
	1	Cordless electric screw driver
		Assorted long reach masonry drills
	1	10MHz Oscilloscope

Appendix F: BSI standards

BSI requirements relating to the installation of computer networks

Computer networks

Standard No	Title
ENV 41107	Circuit Switched Networks
BS 7248	Data Communications Equipment (Twisted Pair Cabling)

Local area networks

Standard No	Title
BS 7247	Characters Guide
DD 98	CSMA / CD Networks
ENV 41103	CSMA / CD Networks - End Systems
BS 7246	CSMA / CD Networks - Planning and Installation
ENV 41101	CSMA / CD Networks - Single Networks
ENV 41102	CSMA / CD Networks - Single or Multiple Networks
DD 99	Logical Link Control
ENV 41109OSI	Connection Mode Transport & Connectionless Mode Network Service- Single Token Ring LANs
ENV 41110OSI	Connection Mode Transport & Connectionless Mode Network Service - Token Ring
BS 6531	Slotted Ring Networks
BS 6532	Slotted Ring Networks - Data Terminal Equipment
DD 100	Token Bus Networks
DD 136	Token Ring Networks
ENV 41108	Token Ring Networks - OSI Connection Mode Transport & Connectionless Mode Network Service

Packet switching networks

Standard No	Title
BS 7224	Connection Mode Network Service - Use of X25
ENV 41105	Connection Mode Transport Service - Switched Transport
ENV 41104	Connection Orientated Transmission - Permanent Access
BS 5397 Pt.7	HDLC Procedures
ENV 41901	Start Stop Mode DTE & Packet Mode DTE - Interconnection via PADS
BS 7267	X25 Interworking Unit - Guide to Operation
BS 7219	X25 Packet Level Protocol for Data Terminating Equipment

Electrical

BS 7671	Requirements for Electrical Installation (IEE Wiring Regulations)
BS 6701	Installation of Telecommunication Apparatus
BS 6651	Lightning Protection

Appendix G: Econet interface options for the A3020 and A4000

The A3020 and A4000 computers can accept the standard Econet interface (product code ADF10) This interface has been used on all machines since the Master 128, but fitting it to A3020 and A4000 machines imposes limitations upon the expansion capability of the machine. These limitations also apply to the Interlock (see *The Interlock* on page 44).

Due to the positioning of the Econet upgrade in relation to the mini-podule expansion slot on the A3020 and A4000 it is not possible to use both expansion options simultaneously unless the AEH52 Econet upgrade is used. Users who need Econet capability, and who do not require the use of the mini-podule expansion slot, may fit the ADF10 Econet upgrade.

This appendix describes how to install the ADF10 Econet interface and wire up an appropriate cable if ready-made cables cannot be obtained.

Fitting the ADF10

The A3020 and A4000 have a number of Molex connectors at the rear of the PCB. The network interface (Econet, Ethernet, Interlock etc, and mini-podules are fitted into these:

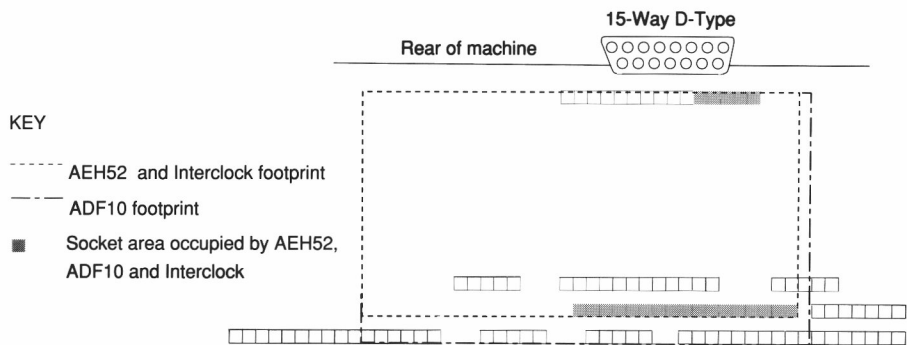

The bottom set of Molex connectors form the mini-podule expansion slot, the remaining connectors are used by the various network interfaces. The greyed out areas illustrate the part of the sockets to which the pins of the Econet interface are fitted.

When fitting this interface in the A3020 and A4000, it is recommended that the support pillars are not used, as this may make replacement of the ADF10 with an AEH52 more complex at a later date.

Adapting the cable

The A3020 and A4000 differ from earlier machines in that the network connector on the rear of the machine is a 15-way D-type connector instead of the 5-pin DIN connector. This means that station leads supplied with the ADF10, for example, cannot be used as it is. Although leads with moulded plugs are more reliable, it is possible to modify the lead supplied with the interface.

The simplest way to make the lead is to take the Econet lead supplied with the ADF10 and cut off one end and solder on a 15-way D-type connector.

Examine the colour coding of the cable used, and make sure that you transfer the colour codes according to this table:

5-pin 180° DIN connector	15-way D-type connector
1	6
2	7
3	8
4	14
5	15

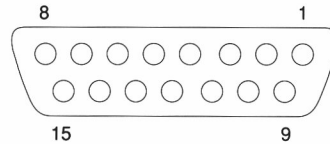
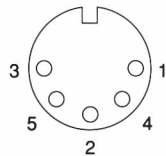

Connections viewed from solder side

Appendix H: Glossary

This glossary defines any new terms that you may have come across in this Guide – mostly those that are specific to networking and to Econet. Terms in italics have their own definition in this glossary.

AUN — Acorn Universal Networking, Acorn's new networking strategy.

backbone network — a *network* the purpose of which is to carry traffic directly from one *network* to another.

bridge — a hardware device used to link together two parts of a physical *network* of the same type (e.g. *Econet*) and to filter out data not destined for either part.

Broadcast Loader — an Acorn product that enables the simultaneous transfer of identical data to a large number of *clients* from a single *station*.

client station — a *station* connected to a *network*.

clock box — a piece of hardware used to supply a clock signal to an *Econet network*.

conduit — another form of *trunking* which is not flush mounted. Internal conduit is normally run along walls; external conduit is used for cabling between buildings and may be subject to fire regulations.

Econet — Acorn's own networking system.

Ethernet — an industry standard networking system offering a greater bandwidth than *Econet*, but at a higher cost.

file server — a *station* on which other *stations* can store and retrieve files.

flag fill — a stream of flags sent onto a *network* by a *bridge* during communication, to prevent other *stations* from using that *network*.

Level 4 File Server — Acorn software that turns an ordinary *station* into a *file server* without the need for specialised hardware.

local network support agency — an Acorn recommended network support specialist; Acorn in Education Centre

net — a part of a *network* that appears to the user as a single entity.

network — a physical network of a single type, delimited by a *bridge* used to connect it to other networks.

network interface — a hardware device used to connect a computer to a *network*, typically produced as a plug in circuit board or as an expansion card.

peripheral — a device, such as a printer or hard disk, connected to the *file server*.

print server — a *station* to which other *stations* can send output for printing.

station — a computer connected to a *net*.

trunking — an enclosed space in which cables can be run; it is either wall mounted, or laid flush with the floor.

Appendix I: Useful addresses

The addresses of some suppliers are listed here; others may be found in your local telephone directory. The inclusion of suppliers' details does not imply any recommendation or endorsement by Acorn Computers Limited of the suppliers or their products.

Acorn addresses

Acorn Computers Limited

Acorn House
Vision Park
Histon
Cambridge
CB4 4AE

Telephone (0223) 254254
Fax (0223) 254262

Acorn Computers New Zealand Limited

INGaire Avenue
PO Box 26-287
Epsom
Auckland 3

Telephone (09) 520 4049
International 010 649 520 4049
Fax (09) 520 3321
Telex A.A. 178559 SATCOM

Acorn Melbourne

12 Gipps St.
Collingwood 3066
Victoria
Australia

Telephone (03) 419 3033
Toll free (008) 032 604
Fax (03) 419 2892

Acorn Sydney

Unit 7
190 George Street
Parramatta 2150
New South Wales
Australia

Telephone (02) 891 655

Fax (02) 635 9641

Health and safety publishers

Health and Safety Commission

St Hugh's House
Stanley Precinct
Bootle
Merseyside
L20 3QY

Telephone:

Publications Dept (051) 951 4223

Switchboard (051) 951 4000

Scriptographic Publications Limited

Channing House
Butts Road
Alton
Hampshire
GU34 1ND

Telephone (0420) 541738

Cable suppliers

BICC Electronic Cables Limited

Helsby Works
Helsby
Warrington
Cheshire
WA6 0DJ

Telephone (0925) 573661

Fax (0928) 24374

Brand-Rex Limited

Viewfield Industrial Estate
Glenrothes
Fife
KY6 2RD

Telephone (0592) 772124
Fax (0592) 775314

Network suppliers

SJ Research Limited

11 The Paddocks
347 Cherry Hinton Road
Cambridge
CB1 4DH

Telephone (0223) 416715
Fax (0223) 416440

Digital Services Limited

9 Wayte Street
Cosham
Portsmouth
Hampshire
PO6 3BS

Telephone (0705) 324934

XOB

Balkeerie
Eassie by Forfar
Angus
DD8 1SR

Telephone (0307) 84364

Component suppliers

RS Components Limited

PO Box 99
Corby
Northamptonshire
NN17 9RS

Telephone (0536) 402888
Fax (0536) 401588

Farnell Electronic Components Limited

Canal Road
Leeds
LS12 2TU

Telephone (0532) 636311
Fax (0532) 633411

Test software suppliers

Alsystems

47 Winchester Road
Four Marks
Alton
Hampshire

Telephone (0420) 561111

Static specialists

Static Control Systems / 3M

3M UK plc
Bracknel
Berkshire
RG12 1JU

Telephone (0344) 426726

Static Safe Environments

Computer House
127 Hagley road
Birmingham
B16 8XU

Telephone (021) 454 8238
Fax (021) 454 8114
Telex 339175 WELCON G

Interference specialists

WJ Furse Limited

Wilford Road
Nottingham
NG2 1EB

Telephone (0602) 863471
Fax (0602) 860538
Telex 377065

Telematic Systems Limited

Alban Park
St. Albans
Hertfordshire
AL4 0XY

Telephone (0727) 833147
Fax (0727) 850687

Galatrek International Limited

Scotland Road
LLanrwst
Gwynedd
LL26 0AL

Telephone (0492) 640311
Fax (0492) 641828
Telex 617114 GALAHU

Claude Lyons Limited

Hoddesdon
Hertfordshire
EN11 9DX

Telephone (0992) 467161
Telex 22724 CLHOD G

Advance Electronics Limited

P.O. Box 230
Wrexham
Clwyd
LL14 3JR

Telephone (0978) 821000
Telex 61424

Belling Lee Intec Limited

540 Great Cambridge Road
Enfield
Middlesex
EN1 3QW

Telephone (071) 367 0080
Fax (071) 367 7595

Rhopoint Systems Limited

Oxted
Surrey
RH8 9BB

Telephone (0883) 722222
Fax (0883) 717245

Rental equipment suppliers

First Rental Limited

P.O. Box 19
Newark Close
York Way
Royston
Hertfordshire

Telephone (0763) 247251
Fax (0763) 242106
Telex 818887

Livingston Hire

Livingston House
Queens Road
Teddington
Middlesex
TW11 0LB

Telephone (081) 943 5151
Fax (081) 977 6431

IR Group

Dorcan House
Meadfield
Langley
Berkshire
SL3 8AL

Telephone (0753) 580000
Fax (0753) 582843

Appendix J: Circuit diagrams

The following circuit diagrams are illustrated in this section:

- Terminator
- BBC Model B Econet
- Early Econet Module
- Later Econet Module
- Acorn A3020 and A4000 Econet Interface
- Acorn A4 Econet Interface

Terminator

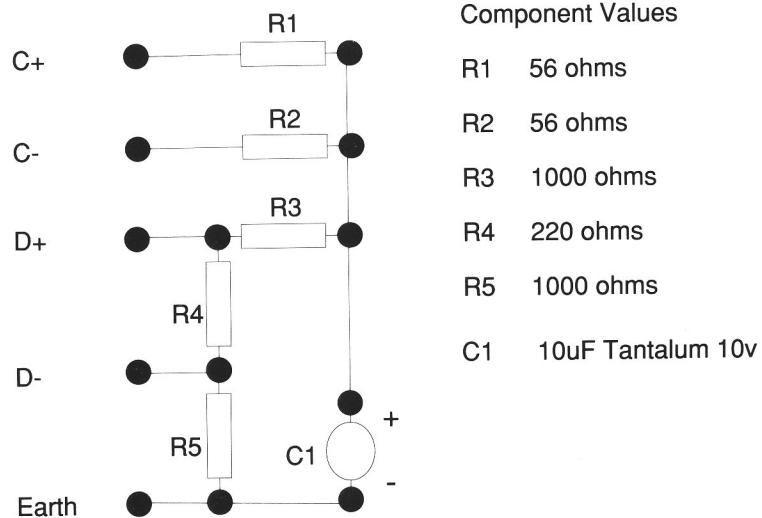

Early Econet Module

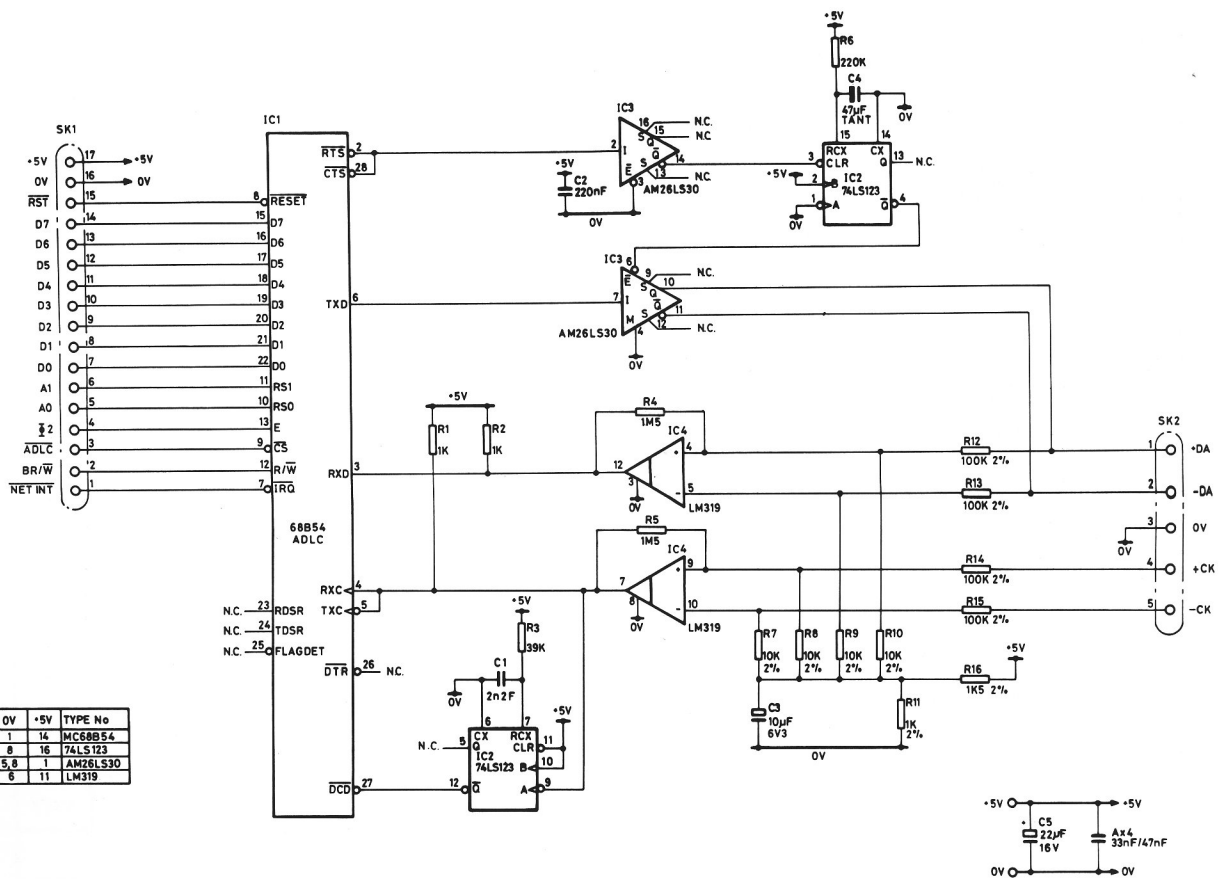
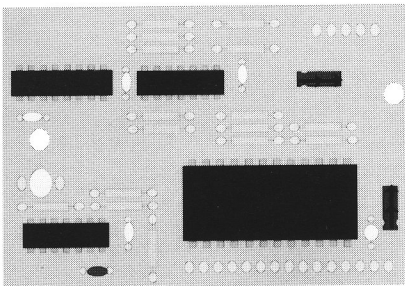

Later Econet Module

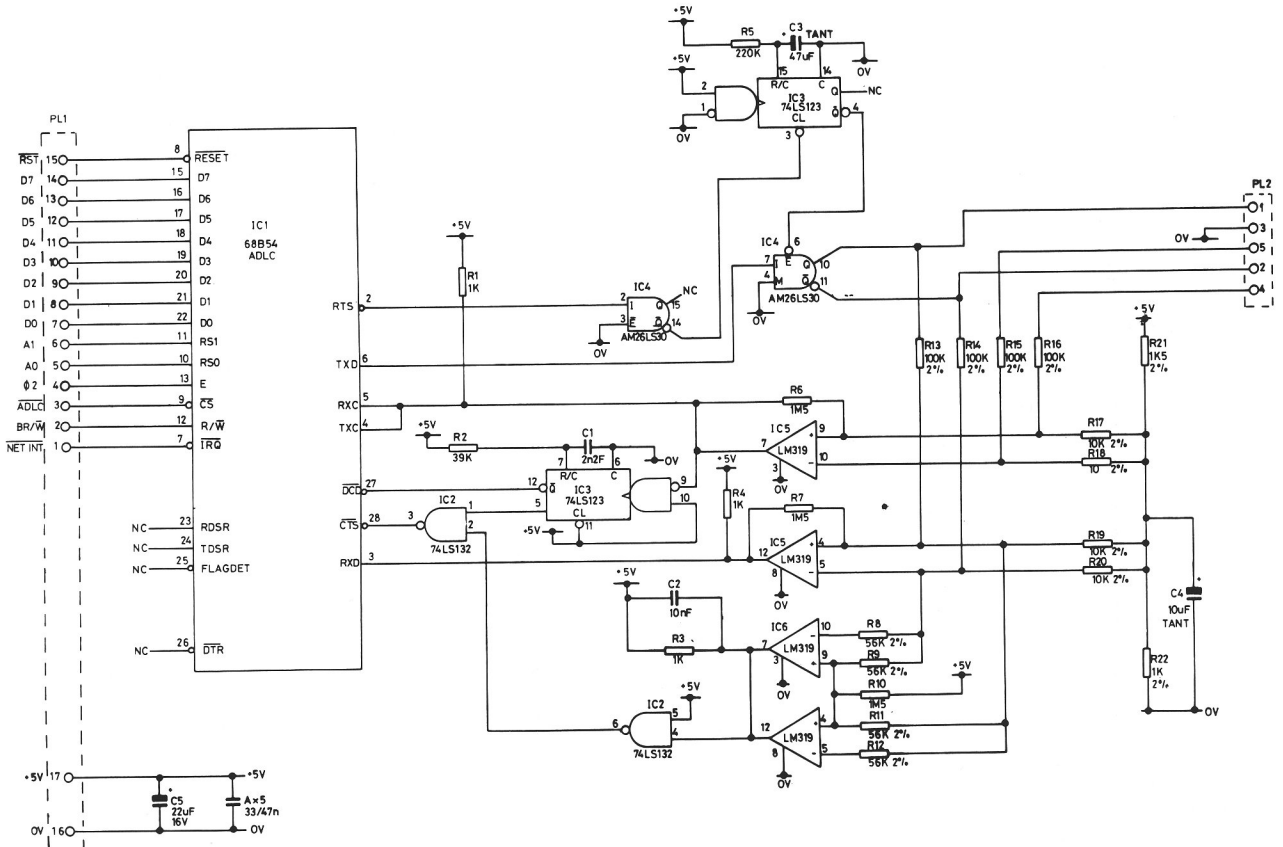
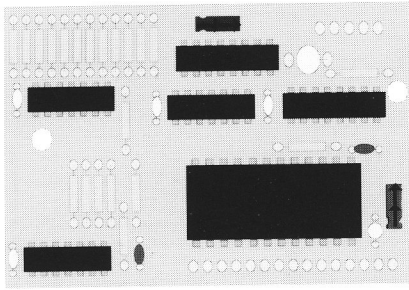

Acorn A3020 and A4000 Econet Interface

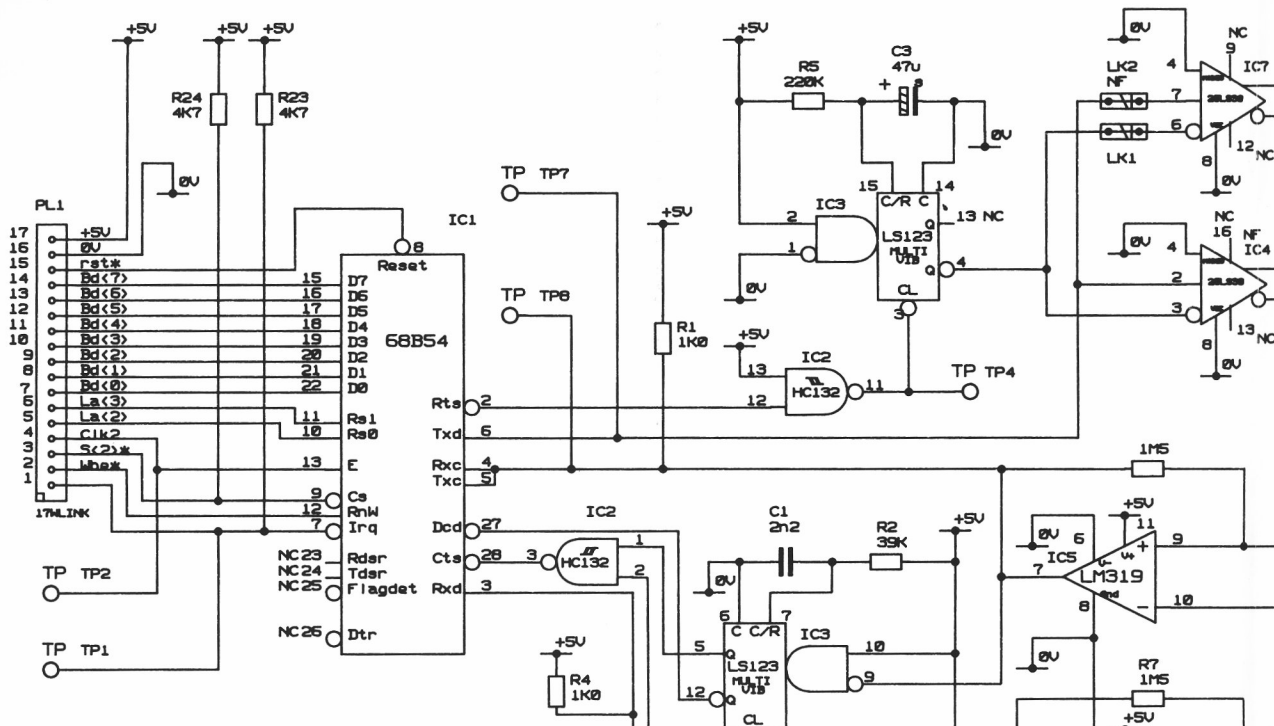

Test Points		
Name	Description	Approximate waveform
TP1	Interrupt out	[Square wave]
TP2	E in (2MHz)	[Square wave]
TP4	Ready to send	[Square wave]
TP5	Data lines OK	[Square wave]
TP6	Received data	[Square wave]
TP7	Transmit data	[Square wave]
TP8	Network clock	[Square wave]

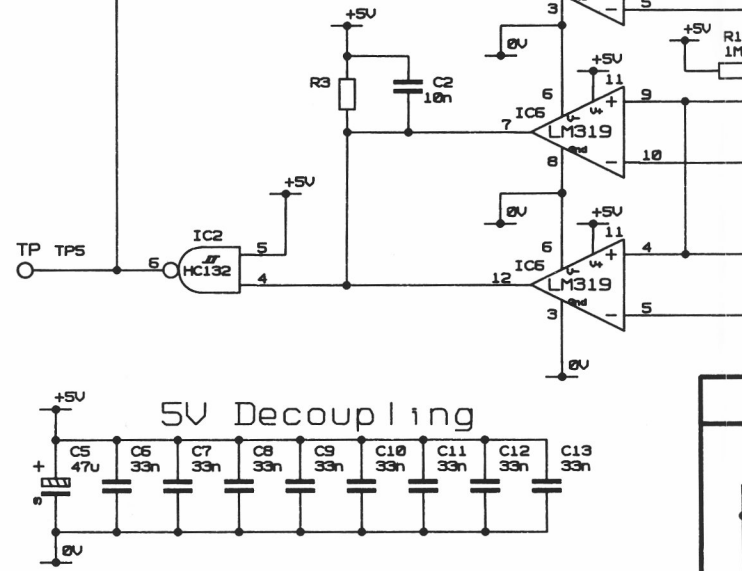

Acorn A3020 and A4000 Econet Interface

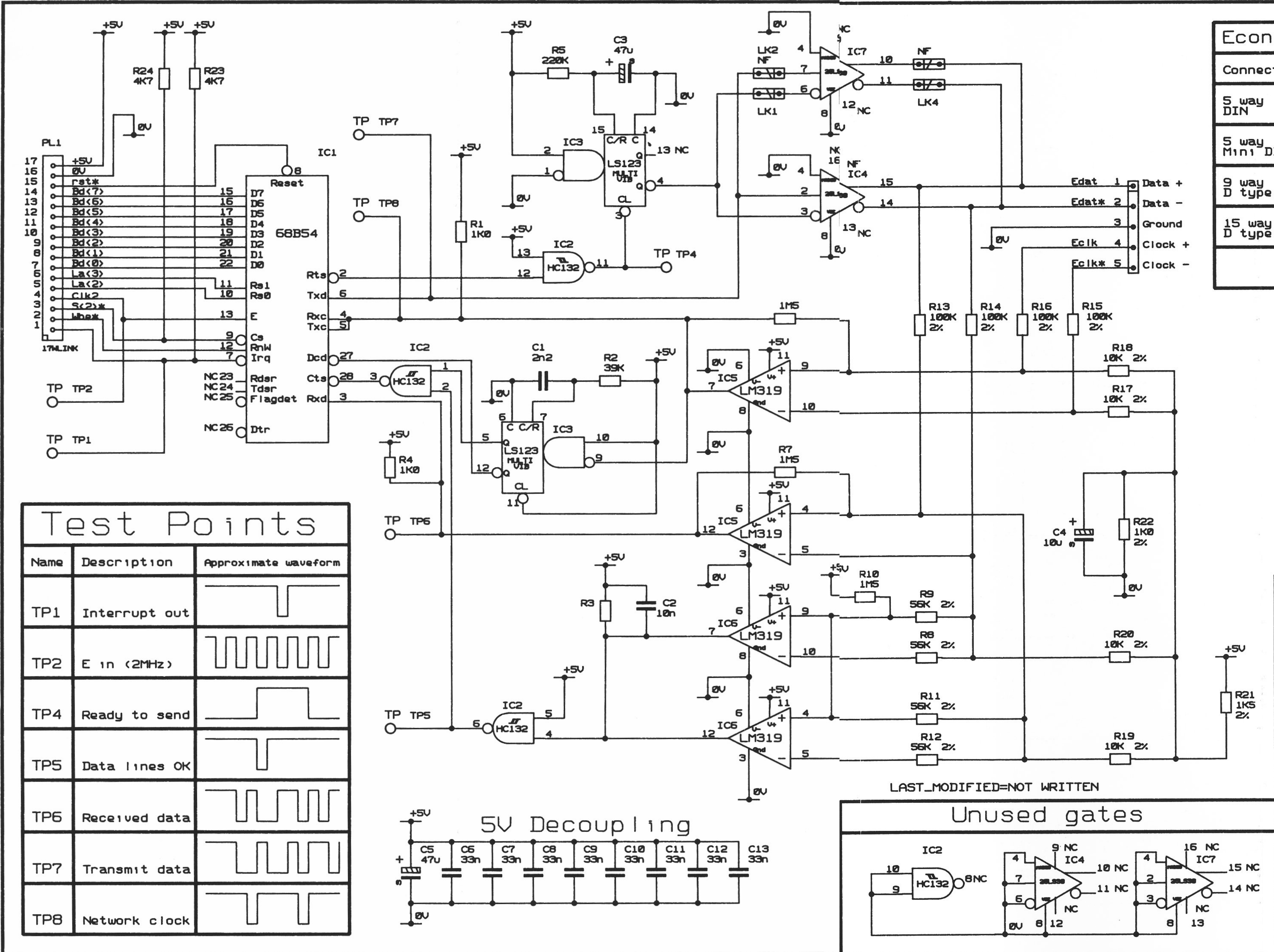

Econet signal connections					
Connector	C+	C-	Gnd	D+	D-
5 way DIN	5	3	2	1	4
5 way Mini DIN	5	3	2	1	4
9 way D type	4	5	7,8	1	2
15 way D type	15	8	7	6	14

Chip	0V	+5V	Part
IC1	1	14	68B54
IC2	7	14	74HC132
IC3	8	16	74LS123
IC4	5,8	1	AM26LS30
IC5	6,8	11	LM319
IC6	6,8	11	LM319
IC7	5,8	1	AM26LS30

Test Points		
Name	Description	Approximate waveform
TP1	Interrupt out	[Square wave]
TP2	E in (2MHz)	[High frequency square wave]
TP4	Ready to send	[Pulse]
TP5	Data lines OK	[High level]
TP6	Received data	[Square wave]
TP7	Transmit data	[Square wave]
TP8	Network clock	[Square wave]

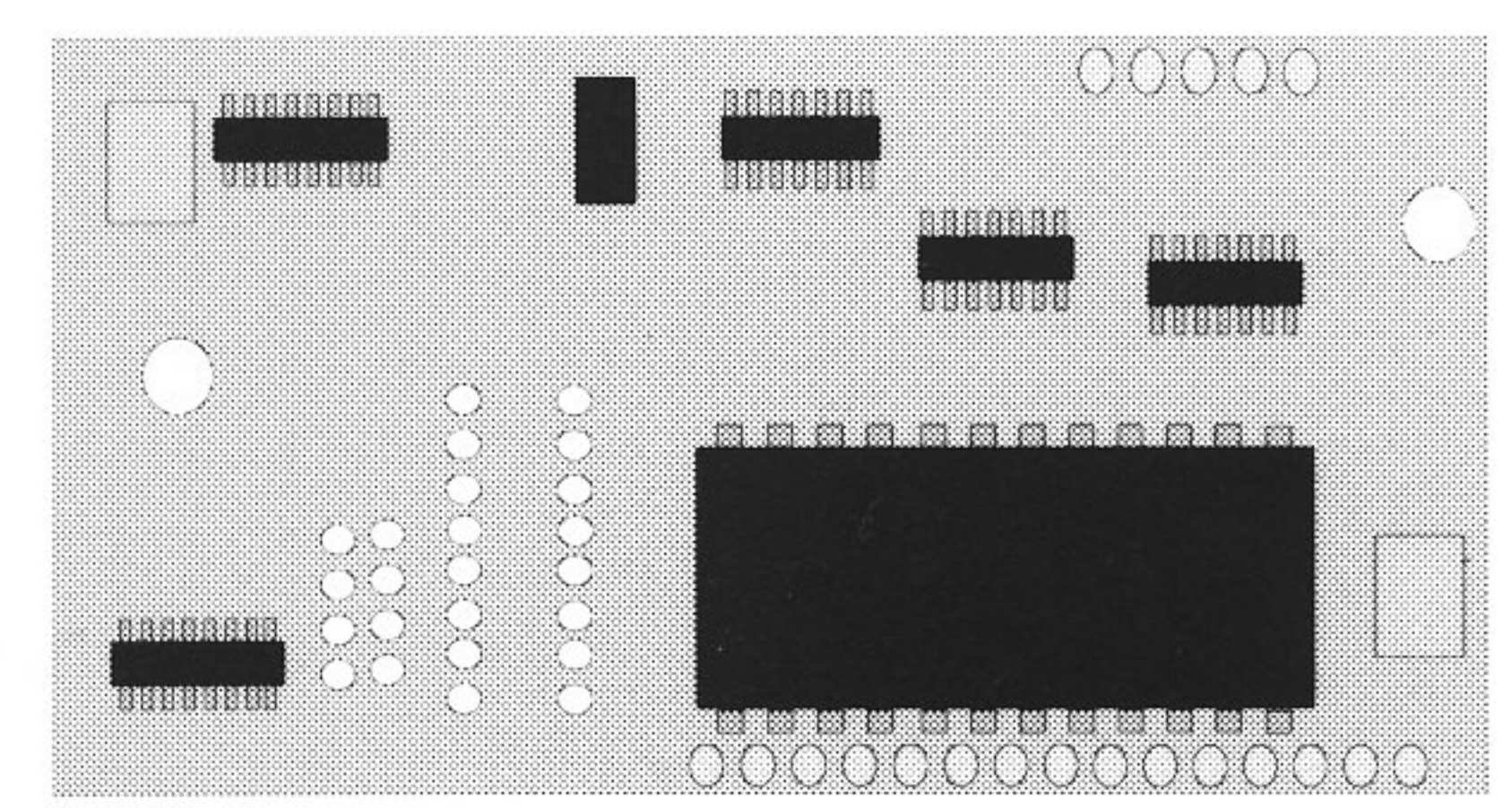
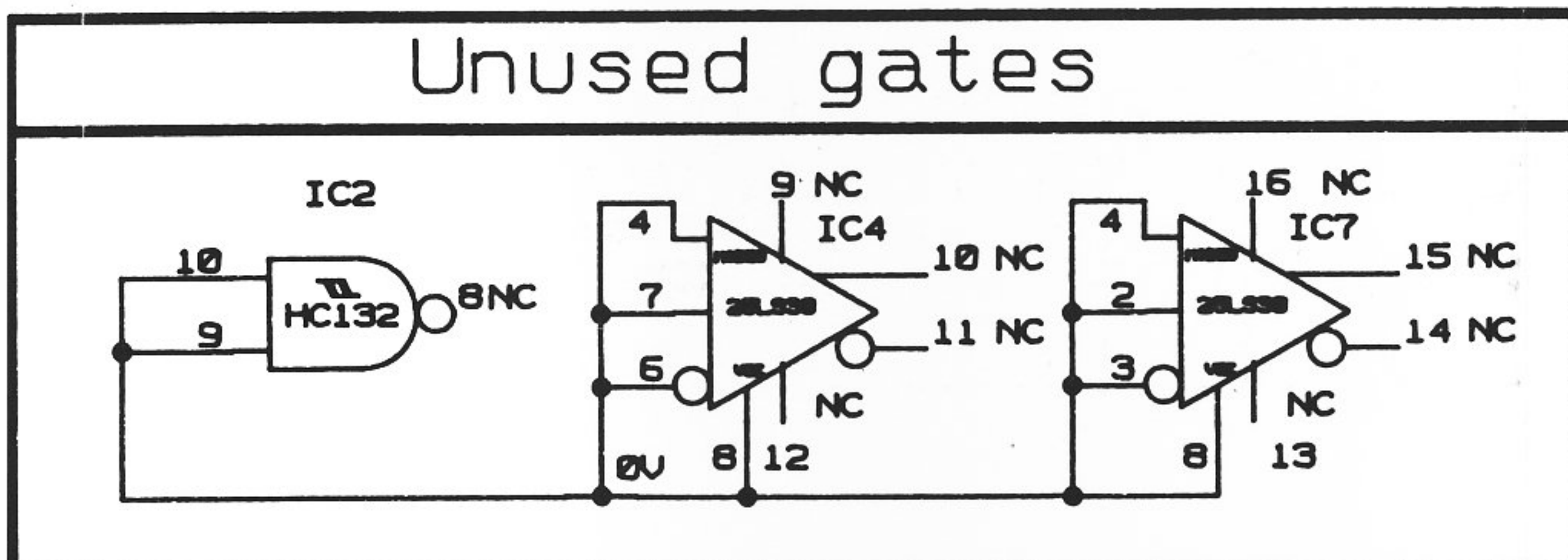
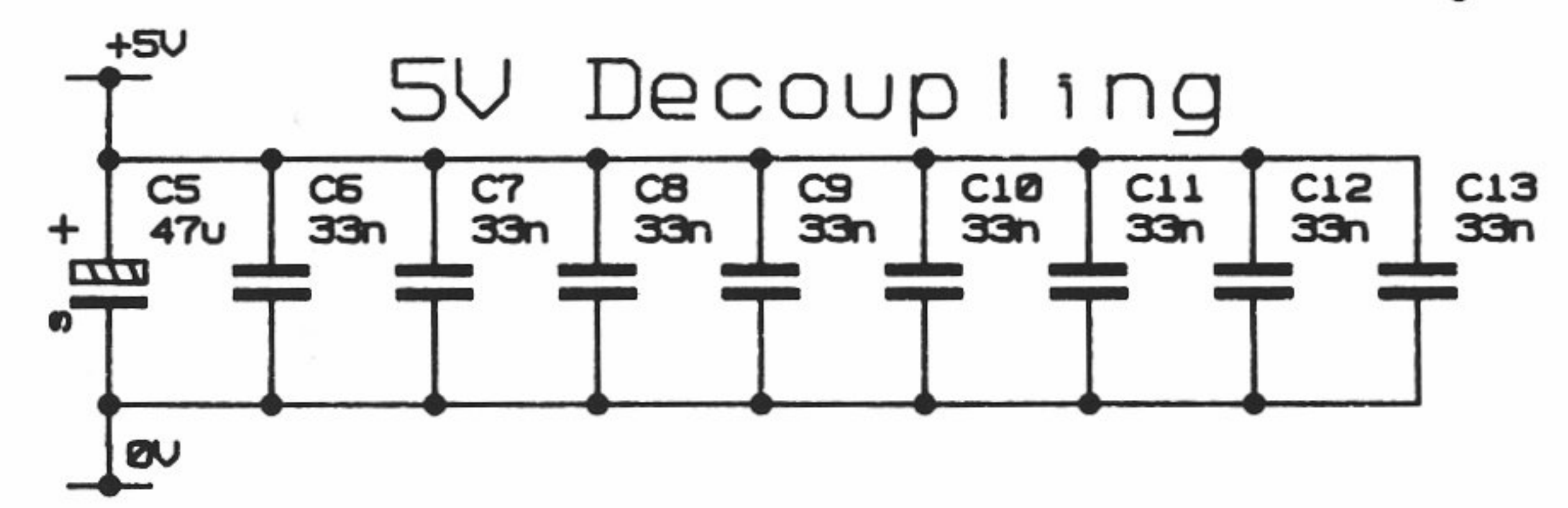

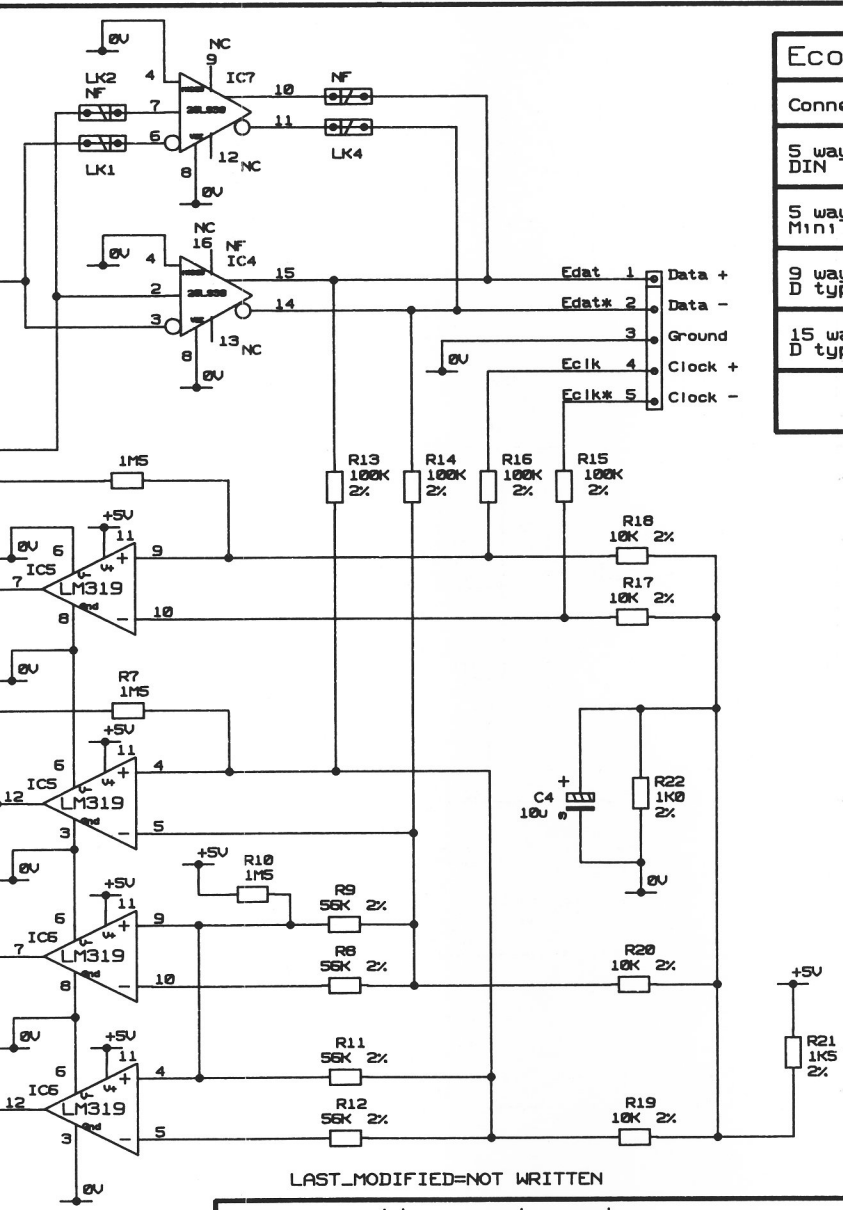

Econet signal connections

Connector	C+	C-	Gnd	D+	D-
5 way DIN	5	3	2	1	4
5 way Mini DIN	5	3	2	1	4
9 way D type	4	5	7, 8	1	2
15 way D type	15	8	7	6	14

Chip	0V	+5V	Part
IC1	1	14	68B54
IC2	7	14	74HC132
IC3	8	16	74LS123
IC4	5, 8	1	AM26LS30
IC5	6, 8	11	LM319
IC6	6, 8	11	LM319
IC7	5, 8	1	AM26LS30

LAST_MODIFIED=NOT WRITTEN

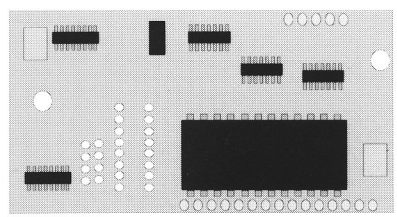
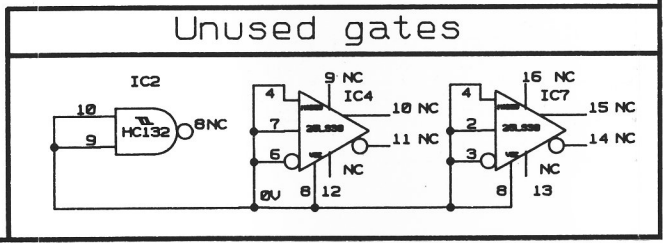
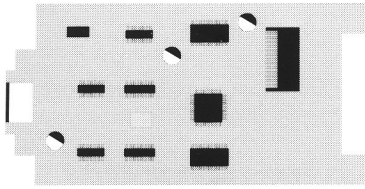

Table 1	
Year	Value
2010	100
2011	105
2012	110
2013	115
2014	120
2015	125
2016	130
2017	135
2018	140
2019	145
2020	150

Table 2	
Year	Value
2010	200
2011	210
2012	220
2013	230
2014	240
2015	250
2016	260
2017	270
2018	280
2019	290
2020	300

Table 3	
Year	Value
2010	300
2011	310
2012	320
2013	330
2014	340
2015	350
2016	360
2017	370
2018	380
2019	390
2020	400

Acorn A4 Econet Interface



Circuit diagram bound separately

Reader's Comment Form

Acorn Econet Design and Installation Guide

We would greatly appreciate your comments about this Manual, which will be taken into account for the next issue:

Did you find the information you wanted?

Do you like the way the information is presented?

General comments:

If there is not enough room for your comments, please continue overleaf

How would you classify your experience with networks?

First-time user

Experienced user

Network manager

Programmer

Cut out (or photocopy) and post to:
Dept RC, Technical Publications
Acorn Computers Limited
Acorn House, Vision Park,
Histon, Cambridge CB4 4AE
England

Your name and address:

This information will only be used to get in touch with you in case we wish to explore your comments further

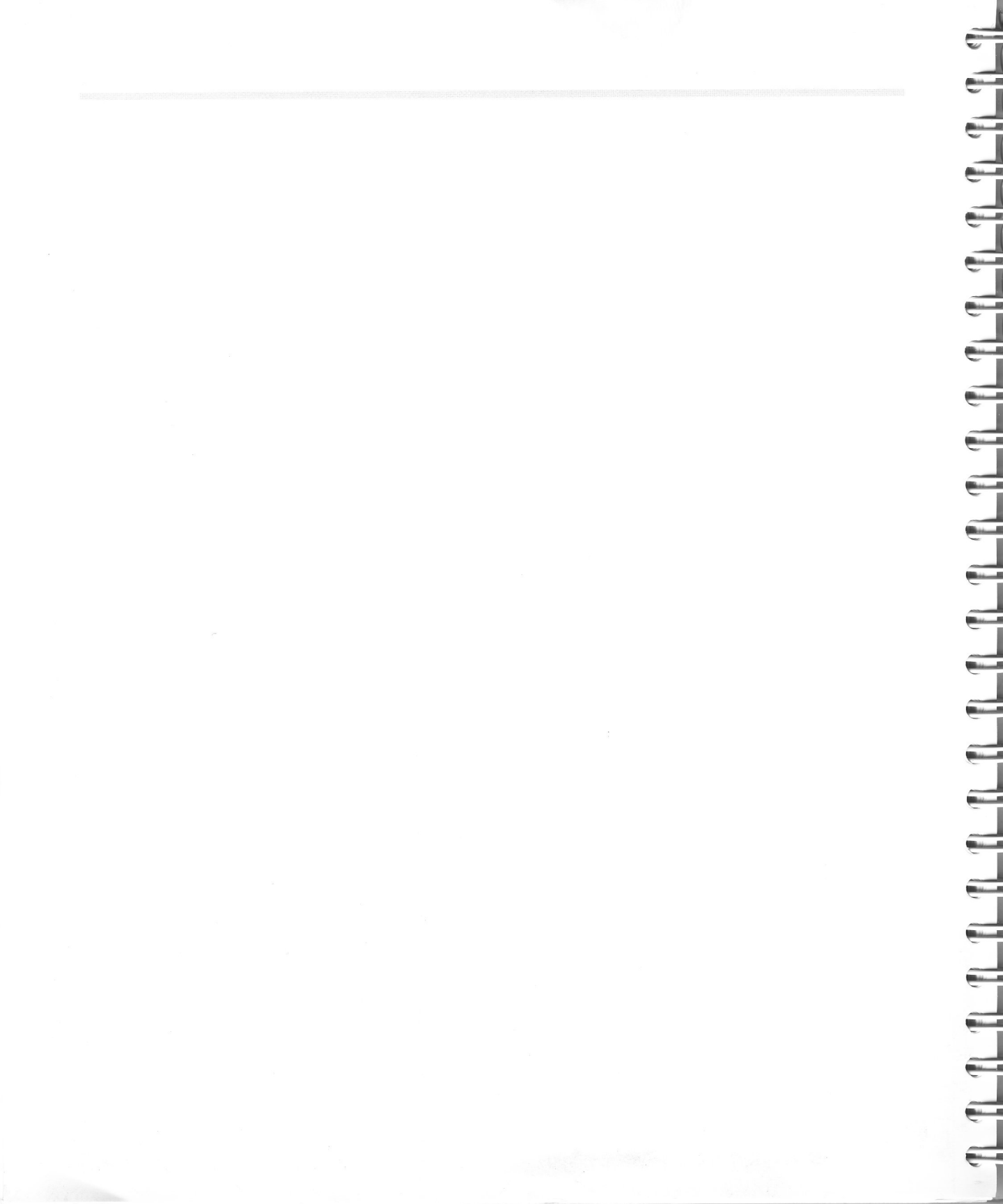



Econet Design and Installation Guide

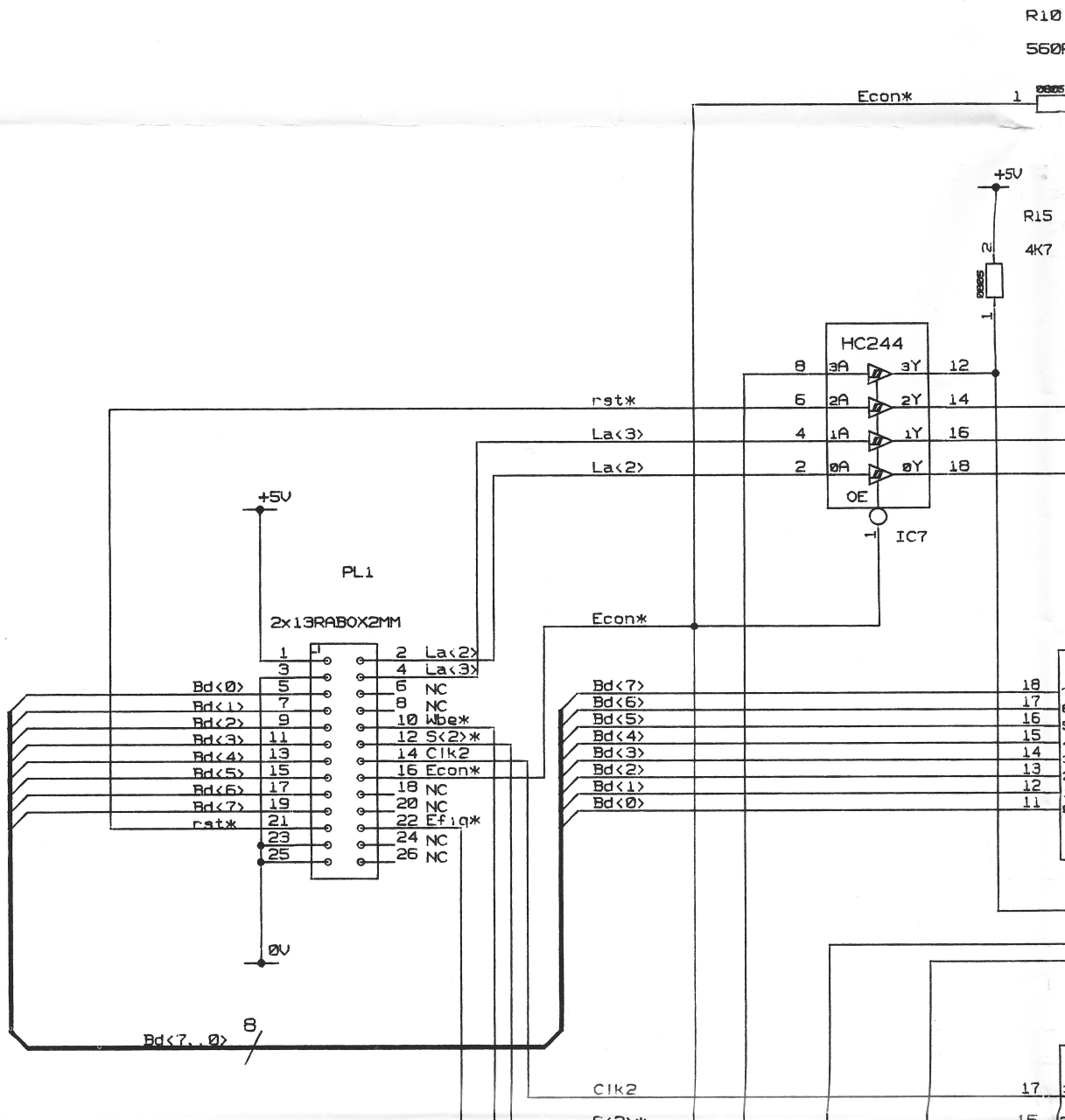

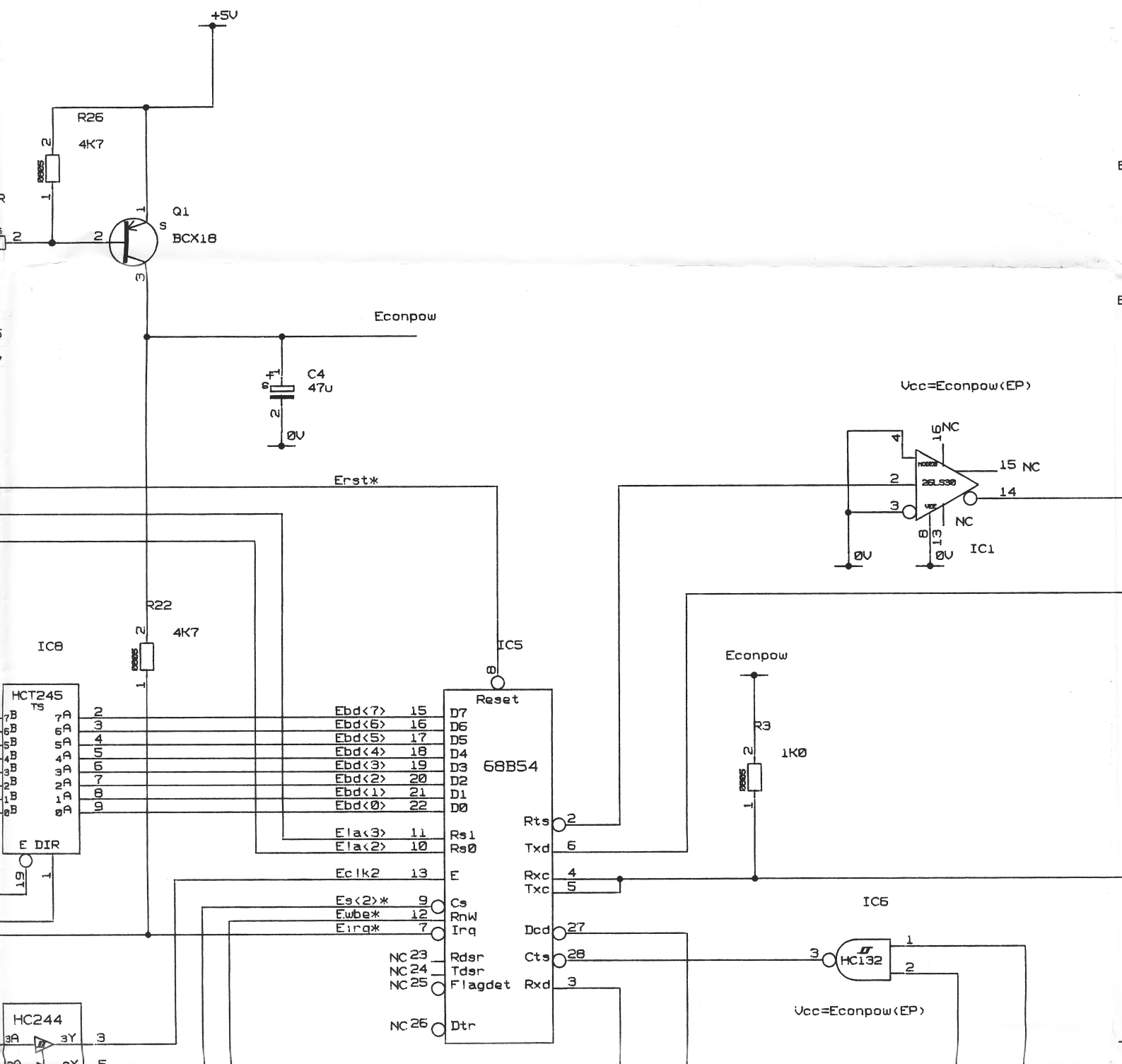

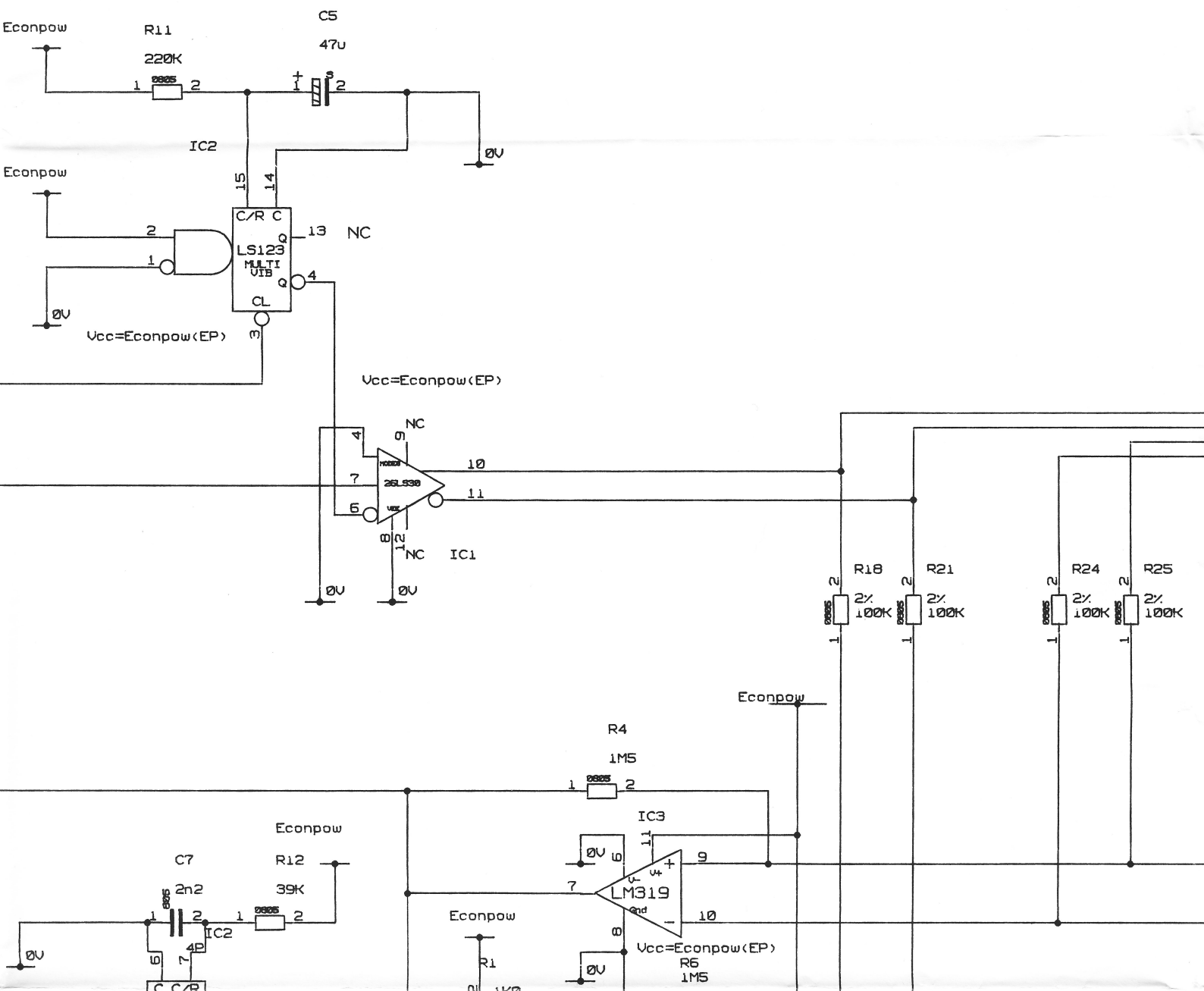

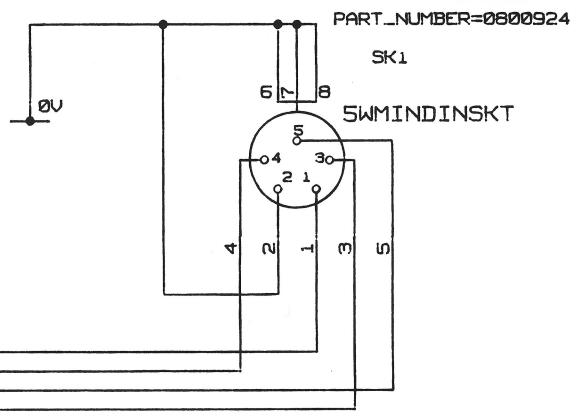

Econpow



R14
2%
1K5

R5 10K 2%

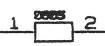

R23 10K 2%



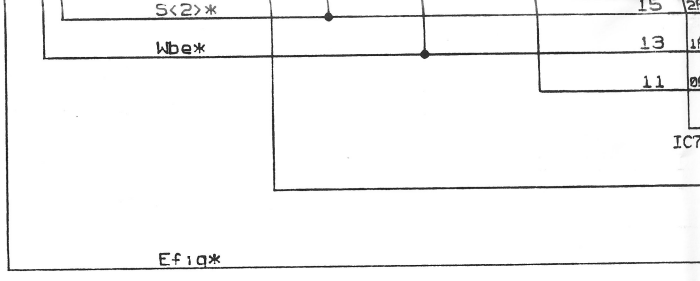

Mechanical spacers

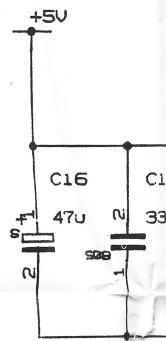
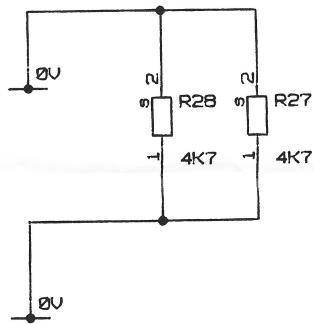

5V Dec

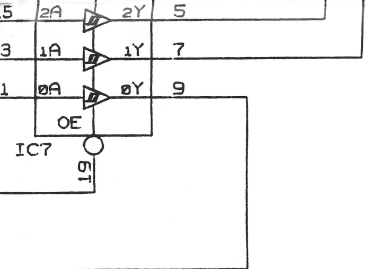

Vcc=Econpow(EP)

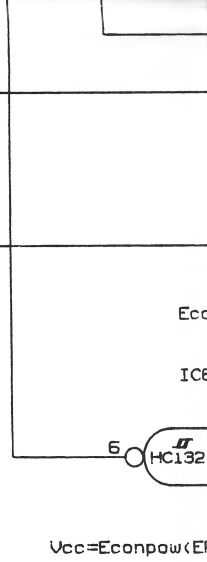
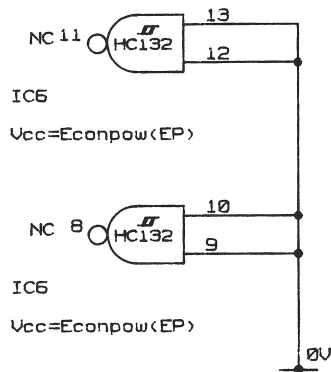

Vcc=Econpow(EP)

Spare gates

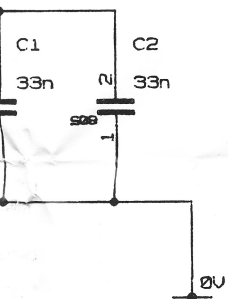

decoupling

Econpow

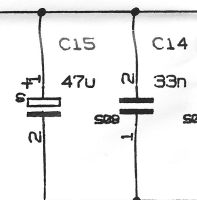

Econ

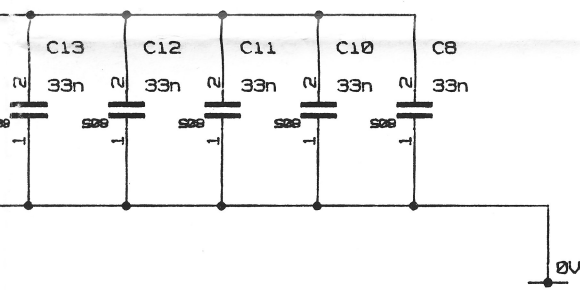
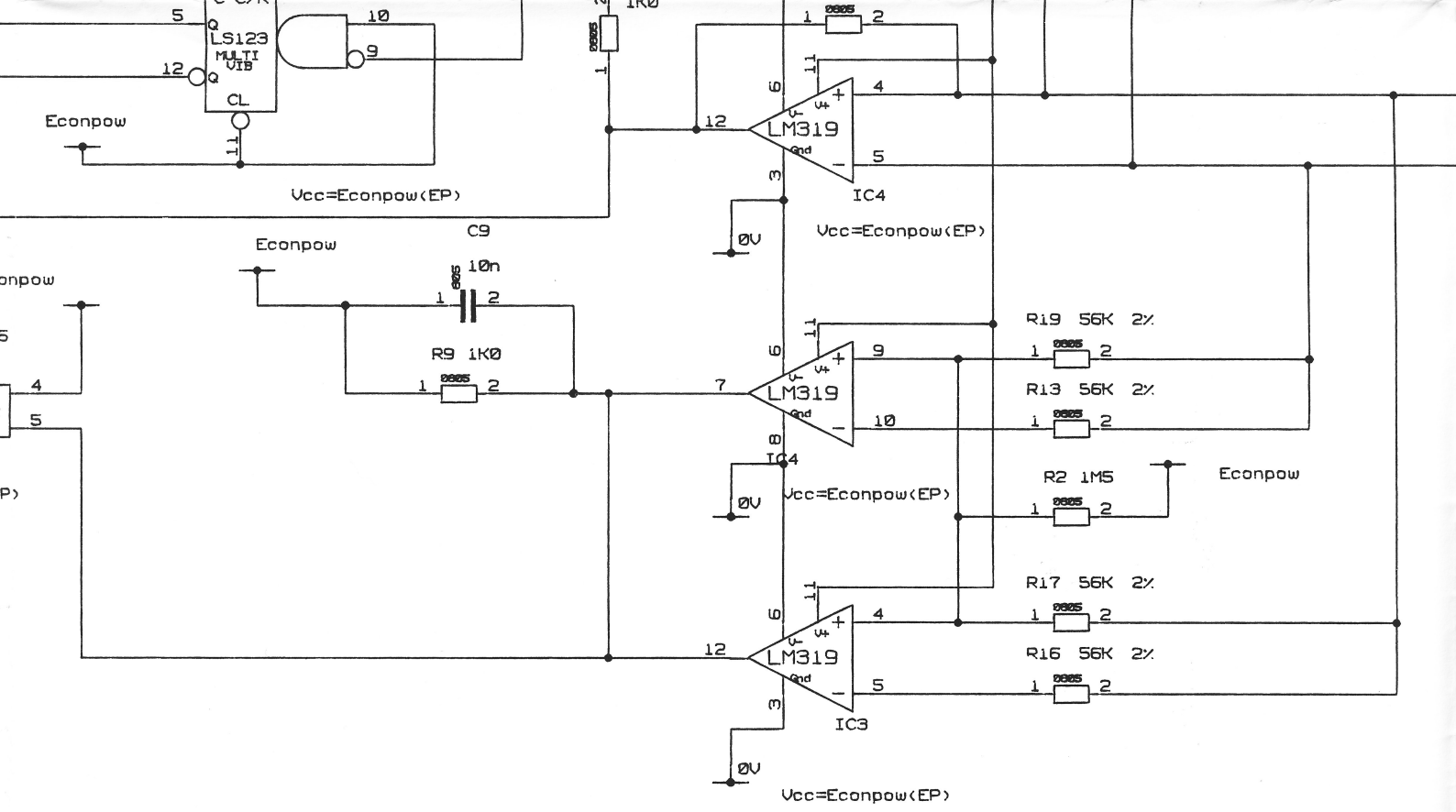

Power Decoupling

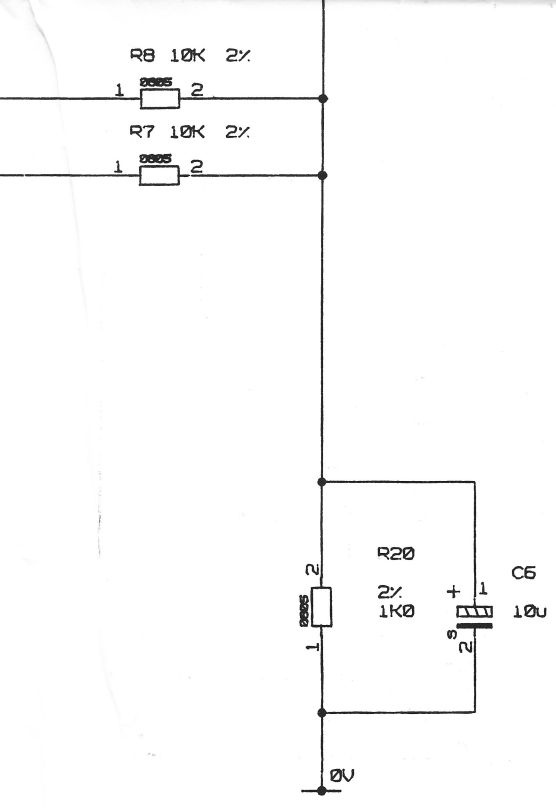

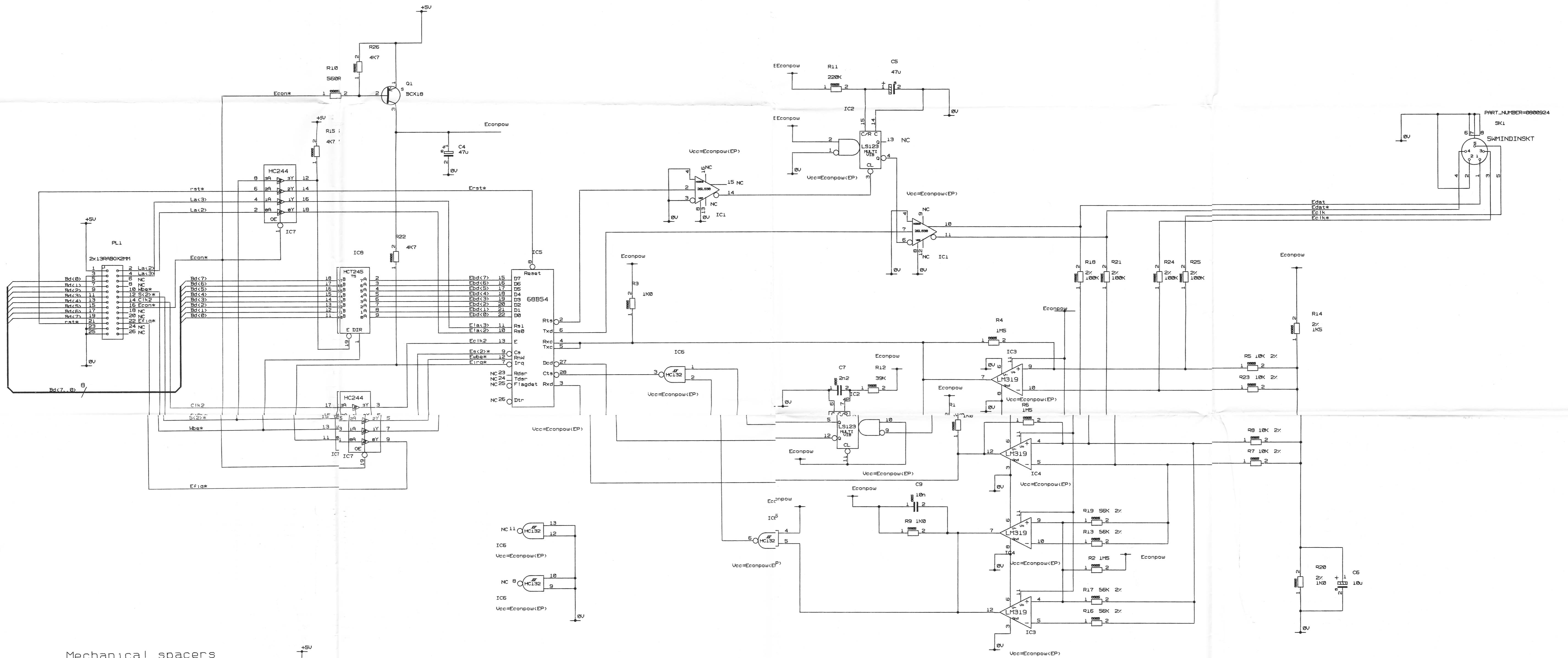

Mechanical spacers

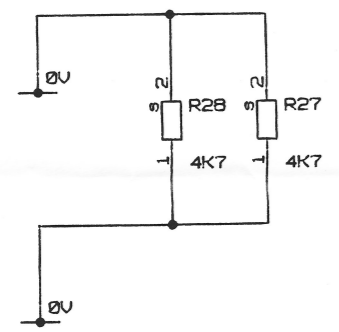

5V Decoupling

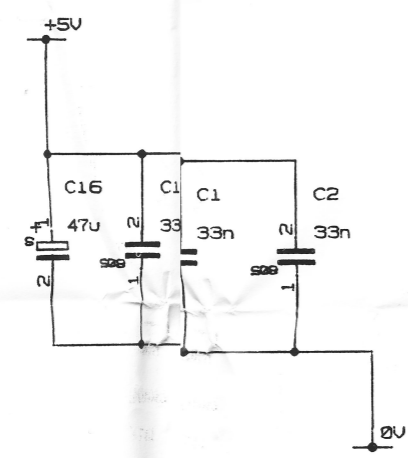

Spare gates

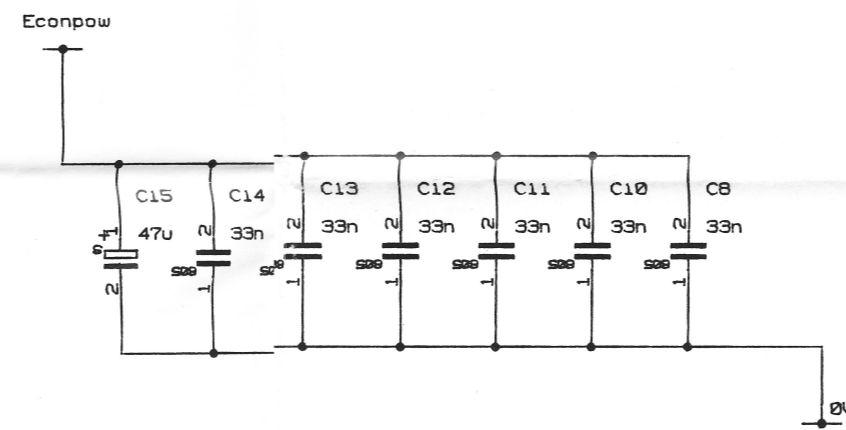

Econpow Decoupling

PART_NUMBER=0800924

